

VIDEOJET 10

Manual

SLD Security & Communications

The Old Forge
Ockham Lane
Ockham
Surrey
GU23 6PH
England

Tel: +44 (0) 1483 225633

Fax: +44 (0) 1483 225634

Email: sales@sld.co.uk

Web: <http://www.sld.co.uk/>

Edition: December 2003 (Version 2.0)

Note

This manual was compiled with the greatest of care and all information double checked. At the time of printing the description was complete and correct. Because of the further development of products, the content of the manual might change without prior notice. We will not be liable for damage which is directly or indirectly due to errors, incompleteness, or discrepancies between the manual and the product described.

Trade marks

All names used in this manual for hardware and software are very probably registered trade marks and must be treated as such.

Contents

Chapter 1 Preface	7
Conventions	7
Intended use	8
EU Guidelines	8
Rating plate	9
Chapter 2 Safety information	11
Electrical shock hazard	11
Installation and operation	12
Repairs and maintenance	12
Chapter 3 Product Description	13
Supplied components	13
System requirements	13
Configuration requirements	13
Operational requirements	14
Functional overview	14
Rear panel connectors	18
Front panel	19
Chapter 4 Installation	21
Connections	22
Switching on/off	25
Setup using a terminal program	26

Chapter 5 Configuration with web browser	31
Establishing the connection	31
Selecting the configuration mode	33
VideoJet 10 transmitter	34
Wizard	34
Expert Mode	38
VideoJet 10 receiver	80
Installation Wizard	80
Expert Mode	82
Function test	101
Chapter 6 Operation	103
Operation with MS Internet Explorer	103
Storing snapshots	107
Storing video sequences	108
Harddisk activity	109
Playback of recorded sequences	109
Back-up	112
Hardware connections between VideoJet units	113
Operation with Software-Decoder	116
Chapter 7 Maintenance and Upgrades	117
Network check	117
Repair	117
Passing on, Disposal	118
Chapter 8 Appendix	119
Faults – possible causes and remedy	119
LEDs	121
Glossary	122
Specifications	125

Chapter 9 Index 127

Preface

1

These Installation and Operating Instructions are intended for persons authorised to install and operate the VideoJet 10. International, national and any relevant regional regulations relating to electronics must be observed at all times. The Operating Instructions explain the installation and operation of the VideoJet 10.

Conventions

In this manual, the following symbols and notations are used to draw attention to special situations:



Warning! or Attention!

This symbol indicates that failure to follow the safety instructions given may directly endanger people, cause damage to the system or to other equipment. The symbol represents a direct threat of danger.



Note

This symbol indicates tips and notes that make using the device easier and more convenient.



Note

This symbol indicates that you might have to find out special information to be able to make the settings or start up the system correctly.

The following typographic conventions are used in this manual:

Configuration	Window and menu names, parameters and buttons
[Enter], [C]	Key names
[Ctrl] + [C]	Two or more keys that are pressed simultaneously.
ping	Command line input and output

Intended use

The Network Video Server VideoJet 10 serves to transmit video, audio and control signals via data networks (Ethernet LAN, Internet). It is designed for use in CCTV systems. The connection of an external alarm generator allows various functions to be triggered automatically. Other applications are not permitted.

In the event of questions concerning the use of the server which are not answered in this manual, please contact:

SLD Security & Communications
The Old Forge, Ockham Lane, Ockham, Surrey GU23 6PH England

Phone +44 (0) 1483 225633

Fax +44 (0) 1483 225634

sales@sld.co.uk

EU Guidelines

The Network Video Server VideoJet 10 complies with the specifications of European Guidelines 89/336 (Electromagnetic Compatibility) and 73/23, amended by 93/68 (Low-Voltage Guideline).

Rating plate

For exact identification, you will find the model designation and serial number on the rating plate on the bottom of the housing. Please note this information here before installation in order to have it to hand in the event of queries or spare parts orders.

Electrical shock hazard

- Never attempt to connect the unit to any power network other than the one for which it was intended.
- Use only the mains lead supplied.
- Do not open the housing.
- Disconnect the power supply unit from the mains power supply and from all other devices if a fault occurs.
- Only install the power supply and the server in a dry place protected from weather.
- If you are uncertain about the safe operation of the unit, shut it down immediately and secure it to prevent any unauthorised start-up. Safe operation is no longer possible, for example,
 - if damage is visible to the unit or the cables,
 - if the unit no longer operates correctly,
 - if the server has been exposed to rain or moisture,
 - if objects have penetrated inside the unit,
 - after long storage under improper conditions or
 - after heavy demands during transport.

Have the system checked in such cases.

Installation and operation

- All applicable electrical codes and regulations must be observed and followed at all times during the installation.
- Before installing or operating the system, ensure that you have read and understood the documentation for other equipment connected to the unit, e.g. cameras. These contain important safety notices and information concerning permissible applications.
- Perform only the installation and operating work described in this manual. All other work beyond this may lead to injuries to persons and damage to the system or other equipment.

Repairs and maintenance

- Never open the housing of the VideoJet 10. The unit contains no parts which you can repair or replace.
- Never open the housing of the power supply unit. The power supply unit contains no parts which you can repair or replace.
- Ensure that only qualified, specialist personnel (electrical technicians) are permitted to carry out maintenance or repair work.

Product Description

3

Supplied components

- Network Video Server VideoJet 10 incl. plug-in power pack
- RS232 Null modem cable
- Brief description "First Steps" German/English
- Software and handbook on CD-ROM

System requirements

- Computer with Windows 98/2000/XP operating system and access to network and
- Web browser Microsoft Internet Explorer (version 5.5 or higher) or free serial interface port and terminal program

Configuration requirements

- Computer with Windows 98/2000/XP operating system and access to network and
- Web browser Microsoft Internet Explorer (version 5.5 or higher) or decoder software, e.g. VIDOS



Note

Make sure the graphic card is set to a color depth of 16 or 32 Bit and the Microsoft Virtual Machine is installed on your computer.

Operational requirements

- Computer with Windows 98/2000/XP operating system and access to network and
 - Web browser Microsoft Internet Explorer (version 5.5 or higher) or decoder software, e.g. VIDOS
- or
- VideoJet 10 acting as receiver and video monitor



Note

Make sure the graphic card is set to a color depth of 16 or 32 Bit and the Microsoft Virtual Machine is installed when displaying video on a computer monitor.

Functional overview

Network video server

The VideoJet 10 is a network video server. Its primary function is to decode and encode video, audio and control data for transmission over an IP network. Via the CompactFlash interface the device can be integrated seamlessly into any wireless LAN using a corresponding card. Because it uses existing networks, rapid and simple integration into CCTV installations via local networks can be achieved.

Two units, i.e. a VideoJet 10 as transmitter and a VideoJet 10 as receiver, can form a stand alone system for data transfer without a PC. The system can be extended to include additional transmitters and receivers so that video images from one transmitter can be simultaneously received on a number of receivers.

Receiver

The appropriate VideoJet 10 or a computer with installed decoding software, e.g. VIDOS or with the installed web browser Microsoft Internet Explorer, can be used as a receiver.

Video encoding	The VideoJet 10 operates with the video compression standard MPEG-4. Thanks to efficient encoding, the data bit rate remains low even with high image quality and, in addition, can be matched into the local environment within wide limits.
Dual Encoding	With Dual Encoding the incoming datastream can be encoded with the help of two different profiles simultaneously which can be set individually. Thus two datastreams are created suiting different needs, e.g. one for local recording and one for transmission over LAN.
Multicast	In suitably configured networks, simultaneous transmission in real time to a number of receivers is possible using the Multicast function. A requirement here is the implementation of the UDP and IGMP protocols on the network.
Remote control	For the remote control of external equipment, e.g. remote pan and tilt heads or motorized zoom lenses, the control data is transmitted via the bidirectional serial interface of the VideoJet 10. This interface is also available for the transmission of transparent data.
Configuration	Configuration of the VideoJet 10 can be carried out using a browser via the local network (Intranet) or from the Internet. Similarly, firmware updates and rapid loading of equipment configurations are also possible.
Recording/ playback	You can save live pictures recorded by the unit as files on the hard disk of your computer. The video pictures are stored in MPEG format and can, for example, be replayed with the MPEG Player included in the delivery. All recordings can be stored locally, too, using a CompactFlash-card or a MicroDrive.
Snapshots	Individual video frames (snapshots) can be called up in JPEG format by the VideoJet 10, stored on the computer hard drive or can be displayed in a separate browser window.

Back-up

Can be accomplished from either the livepage or directly from the Media-Replay mode through a simple mouse click.

Summary

The main functions of the VideoJet 10 can be summarized as follows:

- Video, audio and data transmission via IP data nets
- Dual Encoding with two individually set profiles
- Multicast function for simultaneous transmission to a number of receivers
- Analog BNC composite video input (PAL/NTSC) (transmitter)
- Analog BNC composite video output (PAL/NTSC) (receiver)
- One audio input/output (mono)
- Video and audio encoding to the international standard MPEG-4
- Integrated Ethernet interface (10/100 Base-T)
- CompactFlash interface for memory card or wireless LAN card
- Two transparent bidirectional data channels via serial interface ports RS232/RS422/RS485 and RS232
- Remote control of all internal functions via TCP/IP
- Password protection to prevent unauthorized connection or alterations to configuration
- Closed contact input for external sensor (e.g. door contact)
- Closed contact output for external equipment (e.g. lights or acoustic alarms)
- Event driven automatic connection setup (e.g. on switch-on and with alarms)
- Rapid and user friendly configuration via web browser
- Firmware update through flash memory
- Comfortable configuration upload

Rear panel connectors

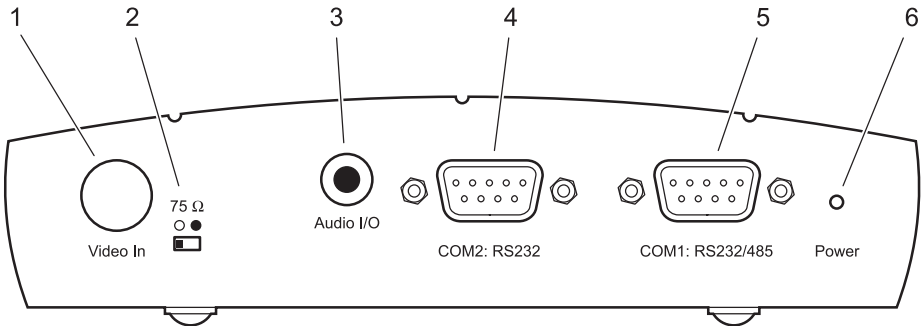

- 1 BNC socket **Video In** (transmitter) or **Video Out** (receiver) for video source or for an analog video monitor
- 2 Slide switch **75 Ω** (transmitter) for termination of the video input
- 3 Bidirectional audio interface **Audio I/O**
3.5 mm stereo jack for connection of a loudspeaker or an audio source (mono line)
- 4 Serial interface port **COM2: RS232**
9-pin sub-D socket (m) for control data transmissions (protocol RS232)
- 5 Serial interface port **COM1: RS232/485**
9-pin sub-D socket (m) for control data transmissions (protocols RS232, RS422 and RS485) and for configuration using terminal software
- 6 **LED Power**
flashes yellow when ready



Note

You can find further information on the LEDs on page 121.

Front panel

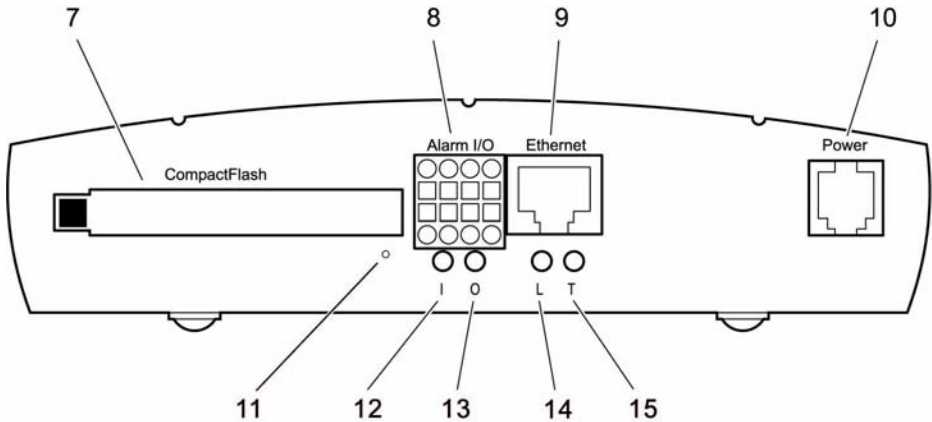

- 7 CompactFlash** interface
drive for CompactFlash cards and MicroDrives
- 8** Screw clamp **ALARM I/O**
for connection of alarm sensors or switches and for switching of external devices (e.g. lamps)
- 9** RJ45 **Ethernet** connector
for connecting to the network
- 10** Socket **Power**
mains cable connector
- 11** Reset button for return to the default settings
- 12** LED **I**
lights up red with active alarm
- 13** LED **O**
lights up green when the relay is switched
- 14** LED **L**
lights up green when the device is connected to the network
- 15** LED **T**
flashes yellow when data packages are transmitted

Due to its compact design and small footprint, the VideoJet 10 can be used as a desk top unit occupying minimum space.



Warning!

The unit is intended for internal use. Select a suitable location for installation where the equipment is not subjected to either extreme temperatures nor to extreme humidity. The ambient temperature must be between 0 and +50 °C, the relative humidity should not exceed 80%.

The equipment becomes warm in normal operation. Ensure that ventilation is adequate and also that there is sufficient clearance between it and heat sensitive objects or equipment.

The following installation requirements must be satisfied:

- Do not mount the equipment in close proximity to heaters or other sources of heat. Avoid locations subject to direct sunlight.
- Allow sufficient space for laying of cables.
- Ensure adequate ventilation of the equipment.
- Only use the cables supplied when connecting up the equipment or, if necessary, use cables suitably screened for interference.
- Position and lay all cables where they will not be subject to damage and ensure strain relief is provided where necessary.

Connections

Camera/monitor Depending on the device model used, you can connect a video source (transmitter) or a monitor (receiver). All cameras and video sources generating a standard PAL or NTSC signal and all monitors suitable for standard PAL or NTSC video signals can be used for this purpose.

☞ Connect the video monitor using video cable (75 Ohm, BNC connector) to the BNC socket **Video Out** of a transmitter.

or

☞ Connect the camera or other video source using video cable (75 Ohm, BNC connector) to the BNC socket **Video In** of a receiver.

☞ Set the slide switch **75 Ω** on the front of the transmitter to **•** to terminate the video input when the video signal is not lopped through.

Network The VideoJet 10 can be connected to a 10/100 Base-T network either directly or via a hub. For this purpose use standard UTP Cat 5 cable with RJ45 connectors.

☞ Connect the network cable to the socket **Ethernet**.

As an alternative the VideoJet 10 can be integrated into a Wireless LAN via the Compact Flash slot. Use an adequate Wireless LAN card.

☞ Insert the Wireless LAN card into the Compact Flash slot.

Alarm input/output The alarm input is provided for switching an external alarm generator, e.g. a door contact or sensor. Using the appropriate configuration an alarm generator, for example, can activate the automatic connection setup between the VideoJet 10 and a remote location.

A voltage free closing contact or switch can be used as activator.



Note

When possible, a switch with a minimum contact bounce should be used as an activator.

The VideoJet 10 is provided with a relay output for switching external equipment, e.g. lamps or acoustic alarms. This switched output can be manually activated during an active connection with the VideoJet 10. In addition, when suitably configured the output can be activated as a response to an alarm signal, for example, to automatic acoustic alarms or to other devices.



Warning!

The maximum rating of the relay contact is 30 V and 1 A.

- ☞ Remove connector block from **Alarm I/O** socket.
- ☞ Insert conductor into connector and secure tightly – check that screws are securely tightened.
- ☞ Replace the connector firmly back onto the **Alarm I/O** socket.

Microphone/ loudspeaker

The VideoJet 10 provides an audio channel via the jack **Audio I/O**. The bidirectional audio signals are simultaneously transmitted along with the video signals. This can be used to drive a loudspeaker or door communication system as required.

- ☞ Connect an audio source (mono line) to the jack **Audio I/O** of the transmitter.
- ☞ Connect the loudspeaker to the jack **Audio I/O** of the receiver.

Data interfaces

The bidirectional data interface ports are intended as control ports for equipment connected to the VideoJet 10, e.g. a dome camera with motorized lens.

The port **COM1: RS232/485** supports RS232, RS422 and RS485 transmission protocols.

The availability of equipment which can be controlled in this way is constantly being extended. Specific information for the installation and control of such units can be obtained from the manufacturer of the equipment involved.



Warning!

Pay particular attention to any associated documentation relating to the installation and operation of equipment being controlled. These documents contain important safety instructions and information regarding permitted applications.



Note

The transmission of transparent data is only possible when a video connection has been established.

Switching on/off

Mains connection Included with the VideoJet 10 is a power supply unit.



Warning!

Use only the plug-in power supply unit supplied for operation of the VideoJet 10. Ensure that the mains supply is free from interference such as voltage surges, spikes or brownouts by using suitable mains conditioners where necessary.

Only connect the VideoJet 10 to the power source after all other connections have been established.

The VideoJet 10 is not provided with a power switch. The unit is ready for operation as soon as the unit is connected to the power.

- ☞ Insert the mains socket into the connector **Power**.
- ☞ Connect the plug-in power supply into an earthed socket. During the start the LED **Power** lights up red. The device is ready as soon as the LED **Power** lights up green.

If the network connection has also been established correctly, the green LED **L** also lights up. A flashing yellow LED **T** signals the transport of data packages over the network.

Setup using a terminal program

Data terminal A data terminal may be connected to the VideoJet 10 for setup and local control. The data terminal usually consists of a computer with suitable terminal software. The standard serial null-modem cable included in delivery is required for the connection.

HyperTerminal, which comes with Windows, can be used as the terminal program.



Note

Information on the installation and use of HyperTerminal can be found in the documentation or in the Online Help for MS Windows.

-
- ☞ Before working with the terminal program, isolate the unit from the data network.
 - ☞ Connect the sub-D socket **COM1: RS232/485** of the VideoJet 10 to a free serial port on the computer.

Terminal configuration

To establish communications between the Terminal program and the VideoJet, the transmission parameters must be correctly setup. The following parameters should be selected in the Terminal program:

- 19,200 Baud
- 8 Data bits
- No parity check
- 1 Stop bit
- No protocol

Command entry After the connection has been established, call up the main menu. Additional submenus and functions are called up using the onscreen commands.

- Switch local echo off so that values entered are not repeated.
- Enter only one command at a time.
- When a value is entered (e.g. IP address) recheck the characters entered and only then press the [ENTER] key to transmit the value to the VideoJet 10.

IP address To operate the VideoJet 10 on a network, an IP address valid for the network must be provided.

The following address has been preset at the factory:

Transmitter: **192.168.0.1**

Receiver: **192.168.0.2**

- ☞ Start up the terminal program, e.g. HyperTerminal.
- ☞ Enter user name `service`. The main menu will be displayed.
- ☞ Enter `I` to open the **IP** menu.

The submenu for network configuration will be displayed.

- ☞ Enter `i`. The current IP address will be displayed; you will be required to enter a new IP address.
- ☞ Enter the new IP address and press [ENTER]. The new IP address will be displayed and is immediately valid.

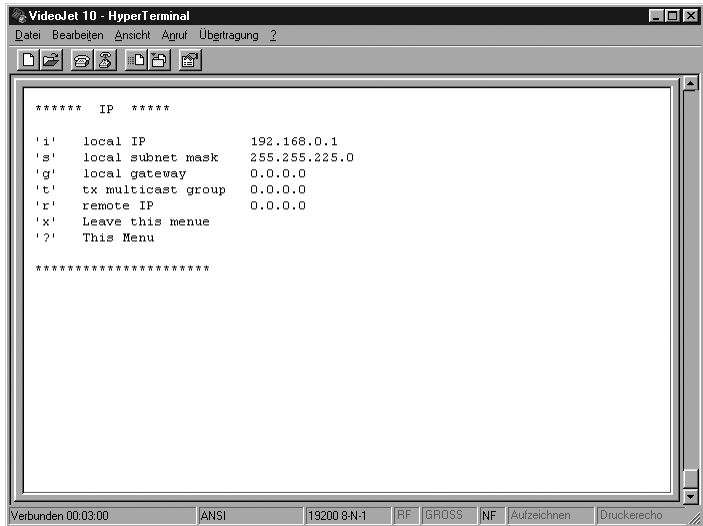

Additional parameters

Using the terminal program, additional basic parameters can be checked and modified where necessary. The onscreen commands displayed in the various submenus are used for this purpose.

PIN assignment COM 1 used as RS232:

	COM1 RS232	COM2 RS232
1	-	DCD (data carrier detect)
2	RxD (receive data)	RxD (receive data)
3	TxD (transmit data)	TxD (transmit data)
4	-	DTR (data terminal ready)
5	GND (ground)	GND (ground)
6	-	DSR (data set ready)
7	RTS (ready to send)	RTS (ready to send)
8	CTS (clear to send)	CTS (clear to send)
9	-	RI (ring indication)

COM 1 used as RS422/485:

	COM1 RS422/485	COM2 RS232
1	-	DCD (data carrier detect)
2	RxD+ (receive data plus)	RxD (receive data)
3	TxD- (transmit data minus)	TxD (transmit data)
4	-	DTR (data terminal ready)
5	GND (ground)	GND (ground)
6	-	DSR (data set ready)
7	TxD+ (transmit data plus)	RTS (ready to send)
8	RxD- (receive data minus)	CTS (clear to send)
9	-	RI (ring indication)

Configuration with web browser

5

Establishing the connection

The integrated HTTP Server provides the option to configure the unit with a web browser over the network. This option offers considerably more possibilities and is more user friendly than configuration using terminal software. In addition, live video images may be displayed.



Note

In order to decode live video images, the required special ActiveX control must be installed on the computer. The latest version of the ActiveX control can be obtained from customer service

Instructions for the operation of the web browser will be found under the online help of the web browser.

System requirements

- Microsoft Internet Explorer (version 5.5 or higher)
- Monitor resolution 1024 × 768 pixels
- Access to network (Intranet or Internet)



Note

Make sure the graphic card is set to a color depth of 16 or 32 Bit and the Microsoft Virtual Machine is installed on your computer.

MPEG decoder installation

If no video images are displayed when MPEG-4 is selected, maybe installation of a current MPEG decoder is necessary. Suitable software for this can be found on the supplied program CD.

- ☞ Insert the CD into the CD-ROM drive of the computer. The CD runs automatically. If the CD does not start automatically, open the root directory of the CD in Windows Explorer and double click on **MPEGAx.exe**.
- ☞ Follow the onscreen instructions.

Establishing the connection

To use the VideoJet 10 on a network, it must be provided with an IP address.

The following address has been preset at the factory:

Transmitter: **192.168.0.1**

Receiver: **0192.168.0.2**

- ☞ Start up the web browser.
- ☞ For the URL, enter the IP address of the VideoJet 10. The Livepage with the video image will be displayed (see page 104).

Selecting the configuration mode

Two possibilities are provided for configuration of the VideoJet 10 or to check the current setup:

- the Installation Wizard
- the Expert Mode.

All settings are retained in VideoJet 10 memory, so that they remain stored even with power interruptions.

Wizard

For initial setup of the unit, operation with the installation wizard is recommended. This takes you step by step through the necessary stages. Important settings for correct operation will not be passed to see. In addition, at each stage short instructions are given to help with the setup process.

Expert Mode

The Expert Mode is only recommended for experienced operators or for system administrators. All unit parameters can be accessed. Operations which fundamentally affect the operation of the unit (e.g. software updates) can only be carried out in this Expert Mode.

VideoJet 10 transmitter

On the Livepage, click on the top of the window on the link **Settings**. A new page will be opened and the required installation mode can be selected on the menu line:



Note

The link **Media-Replay** is only displayed when the VideoJet 10 is provided with a storage medium for local recording (e.g. Compact-Flash card).

Wizard

The installation wizard of the VideoJet 10 guides you step by step through the necessary procedures.

Wizard start-up

The installation wizard can be started by clicking on the link **Settings** on the Livepage.

- ☞ Click on the link **Wizard**. A new page will be displayed.
- ☞ On the installation wizard field click on the button with the wizard symbol. The Wizard window will open up.
- ☞ Click on the button **Start** to call up the Wizard.

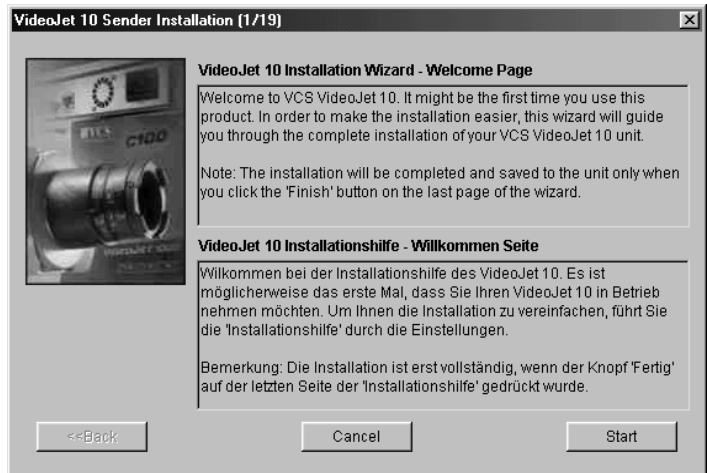

General procedures

When the installation wizard has been started, a new window will open up which contains information and in which settings can be made.

- ☞ Always read the information in the upper section of the window first.
- ☞ Click in the text boxes to enter values or else use the other elements which are available such as buttons, check boxes or list fields.
- ☞ Click on the button **Next >>** to continue to the next stage.
- ☞ To return to a previous screen to check a previous setting click on the button **<< Back**.

- ☞ Click on the button **Cancel**, to interrupt the process and close the installation wizard.

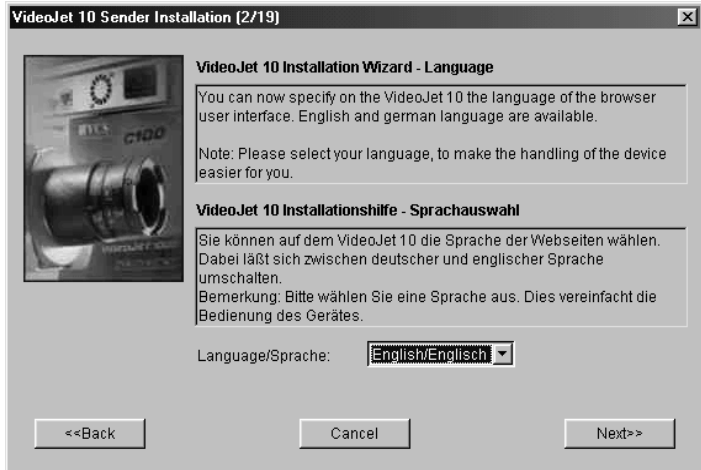

Store changes

Changes called up in the installation wizard are only effective when the button **Finish** on the last page is clicked.

The original settings are retained if the button **Cancel** is clicked.



Warning!

Carry on with the installation wizard to the final screen if possible. This is the only location where all of the changes made can be stored by clicking on the button **Finish**.

Additional settings

On the last page of the installation wizard you are presented with the option of directly starting a further wizard for configuration of the Livepage (application wizard).



- ☞ Select the option **Yes** to start the application wizard.
- ☞ Click on the button **Finish** to close the installation wizard. The setup changes are stored and the application wizard is started immediately.

The application wizard behaves in a similar manner to that of the installation wizard.

Expert Mode

In the Expert Mode, all parameters of the VideoJet 10 can be configured. If any of the configuration pages are called up, the current settings will be displayed. The settings can be altered by entering new values or by selecting from a predefined value in a list field.

Navigation

The Expert Mode is selected by clicking on the link **Settings** while displaying the Livepage.

- ☞ Click on the link **Expert Mode**. The start page is opened.
- ☞ Click on one of the links on the left border of the window. The corresponding page will be opened up.



Note

The link **Media-Replay** in the top of the window and the links **Media partition** and **Recording scheduler** on the left border are only displayed when the VideoJet 10 is provided with a storage medium for local recording (e.g. CompactFlash card).



Store changes

If any of the configuration pages is called up, the current settings will be displayed. The settings can be altered by entering new values or by selecting from a predefined value in a list field. When a change has been entered, click on the associated button **Set** in order to store the change.



Warning!

Store all changes with the associated button **Set**. By clicking on the button **Set** only the changes in the relevant field are stored (blue frame). Changes in any of the other fields are ignored.

Unit identification

Livepage	Wizard	Expert Mode
Unit identification		
Unit name:	<input type="text"/>	
Unit ID:	<input type="text"/>	<input type="button" value="Set"/>
Help on this page?		

Unit name:

Enter a name for the unit here for easy identification of the unit in large installations resp. to support the DNS server functionality.

Unit ID:

Each VideoJet 10 should be assigned a unique identifier which can additionally be used to identify the unit.

Password settings

Livepage Wizard Expert Mode

Password settings

User name:

Password:

Password confirm:

[Help on this page?](#)

User name:

The access to a VideoJet 10 is generally protected with a password in order to prevent unauthorised use of the device. The transmitters operate with three authorisation levels: **live**, **service** and **user**.

In the authorisation level **service**, you can change all the configuration settings after entering the corresponding password.

With the authorisation level **user** you can operate but not configure the device. You can have a live picture or the configuration settings displayed, but you cannot change them.

With **live** you can display a live video but neither change the configuration nor for example control a camera.

Password:

You can define and change passwords for access to the device when you are working with the authorisation level 'service' or if the device is not protected with a password. You can change only one of the three passwords at a time. In order to change the password of another level, you have to call up this configuration page again.

Password confirm:

Enter the new password again to rule out the risk of typing errors.

Language selection

Livepage Wizard Expert Mode

Language selection

Website language:

[Help on this page?](#)

Website language:

Here you select the desired language of the HTML pages.

Date and time

Livepage	Wizard	Expert Mode
Date and time		
Date format:	Europe	
Unit date:	Friday	.11.07.2003
Unit time:	15 : 38 : 28	<input type="button" value="Synchr. PC"/> <input type="button" value="Set"/>
Help on this page?		

If a number of VideoJet units are combined in a system, it is important that the internal clocks of the separate units are all synchronized. Only if all units operate with the same time it is possible, for example, to correctly identify and evaluate events which have occurred simultaneously.

Date format:

Select the desired date format here

(Europe: DD.MM.YYYY; USA: MM.DD.YYYY, Japan: YYYY/MM/DD).

Unit date:

Enter the current date here. As the system time is driven by the internal calendar clock, it is not necessary to enter the day of week. This is automatically appended.

Unit time:

Enter the current time here or click on the button **Synchr. PC**, in order to transfer the system time of the computer to the unit.

Timer server

Livepage	Wizard	Expert Mode
Timer server		
Time zone:	(UTC +1:00) Western & Central Europe (MEZ)	
Time server IP address:	0.0.0.0	<input type="button" value="Set"/>
Help on this page?		

The VideoJet 10 can receive a time signal from a TIME server (NTP server) and use it to set the internal clock. The device calls up the time signal automatically every two hours.

Time zone:

Here you select the current time zone.

Time server IP address:

Enter the IP address of a TIME server here.

Camera name

Camera name

Camera:

[Help on this page?](#)

Camera name:

Enter the required camera name here. The camera name is used for easier remote identification of the camera location, e.g. in event of an alarm call. Enter here an unambiguous and clear name

Display stamping

Display stamping

Camera name stamping:

Time stamping:

Alarm mode stamping:

Displayed alarm message:

[Help on this page?](#)

Camera name stamping:

Here you can set the position of the camera name stamping. It can be displayed on **Top** or on **Bottom** of the image or you can define a position yourself via the Hyperterminal and activate it choosing the option **Custom**. If you do not wish the name to be displayed, select **Off**.

Time stamping:

Here you can set the position of the time and date stamping. It can be displayed on **Top** or on **Bottom** of the image or you can define a position yourself via the Hyperterminal and activate it choosing the option **Custom**. If you do not wish time and date to be displayed, select **Off**.

Alarm mode stamping:

Select here the option **On** if it is required to display a text in case of an alarm.

Displayed alarm message:

Enter here the text that is to be displayed in case of an alarm. It can contain up to 31 characters.

MPEG-4 Encoder configuration

The screenshot shows the 'MPEG-4 Encoder configuration' web interface. At the top, there are three tabs: 'Livepage', 'Wizard', and 'Expert Mode'. The 'Expert Mode' tab is selected. Below the tabs, the main title is 'MPEG-4 Encoder configuration'. Underneath, there are two sub-tabs: 'MPEG-4 Encoder 1' (which is active) and 'MPEG-4 Encoder 2'. The configuration fields for 'MPEG-4 Encoder 1' are as follows:

- Name of first encoder:
- Parameter preset:
- Preset parameter name:
- Datarate: (kBit/s)
- Video quality settings: with a slider from 'High' to 'Low'
- Intra frame distance:
- Frame skip ratio:
- Video resolution:
- Reset this parameter preset:

At the bottom left, there is a link: [Help on this page?](#)

The VideoJet 10 transmitter provides two MPEG-4 video encoder that can be configured separately. The benefit of this so called dual encoding is that you can transmit and record simultaneously with different compression parameters. The data transmission parameters can be configured to suit the local operating environment (e.g. network architecture, bandwidth, data structures).

For both of the MPEG-4 encoders several preprogrammed profiles are available which are optimized for different modes of transmission. You can change these profiles individually in the Expert Mode by inserting the parameter values wanted. It is advisable to give a new name to the modified profile to facilitate recognition. Click on the respective tab to switch between the parameters of the two

encoder. On the page **Livepage configuration** you decide which encoder is to be shown on the Livepage (see page 75).

Name of first (second) encoder:

Enter here a unique name for the respective encoder.

Parameter preset:

Eight preprogrammed profiles are available for each of the two MPEG-4 encoder which are optimized for different modes of transmission:

- **high quality (CIF)**
for connections with high bandwidth, resolution 352 × 288
- **high resolution (2CIF)**
for connections with high bandwidth, resolution 704 × 288
- **small resolution (QCIF)**
for connections with low bandwidth, resolution 176 × 144
- **DSL**
for DSL connections with 500 kBit/s
- **ISDN (2B)**
for ISDN connections over two B channels
- **ISDN (1B)**
for ISDN connections over one B channel
- **MODEM**
for analog modem connections with 20 kBit/s
- **GSM**
for GSM modem connections

By changing the parameter values you can adapt the profiles to your specific needs. After clicking the **Set** button the chosen profile becomes active and changes in the parameters are taken over.



Note

All parameters together make a profile and are dependent on one another. When a parameter value out of range is set the next possible value will automatically be entered when clicking on **Set**.

Preset parameter name:

Enter here a unique name for the chosen resp. modified profile. The name will be taken over into the field **Parameter preset** automatically.

Datarate:

Enter here the datarate for transmission over the network.

Video quality settings:

Here you can adjust the video quality in relation to the frame rate. With the option **Auto** the video quality is set in due proportion to the frame rate automatically. By choosing **Manual** you can set the slider to a value between **1** and **31**. **1** stands for highest quality with a lower frame refresh rate. **31** stands for maximum frame rate at a lower quality.

Intra frame distance:

Here you can define the number of frames up to the proximate I-frame.

**Warning!**

If recordings are to be made a value greater than **0** must be chosen here.

Frame skip ratio:

The chosen number defines which frames are encoded and transmitted. Choosing **4** e.g. only every fourth frame is encoded, the following three frames are skipped. Especially with narrow bandwidth this can be of advantage.

Video resolution:

Select the desired resolution for the MPEG-4 video picture. You can choose out of the following options:

- **QCIF**176 × 144 pixels
- **CIF**352 × 288 pixels
- **2CIF**704 × 288 pixels

Reset this parameter preset:

When the **Default** button is pressed the parameters for the selected profile are reset to the factory default values.

Audio configuration

Livepage Wizard Expert Mode

Audio configuration

Activate audio:

[Help on this page?](#)

Activate audio:

Decide here if you want to send an audio stream along with the MPEG-4 video. Transmission of audio requires additional bandwidth of approx. 80 kBit/s. When audio is set to **On** it is stored together with the video stream when centralized recording is active.



Attention!

The audio stream is only stored with centralized recording, e.g. using VIDOS-NVR. Local storage media can not record audio.

Video input settings

Livepage Wizard Expert Mode

Video input settings

Video input filter:

[Help on this page?](#)

Video input filter:

Adjust the sharpness of the picture here. 'None' means no input filter is used. Set the level to the lowest possible value to avoid noise and artefacts in the picture.



Note

The links to the **Media-Replay** and the configuration pages **Media partition** and **Recording scheduler** are only displayed when the VideoJet 10 is provided with a storage medium for local recording (e.g. CompactFlash card).

Media partition

Livepage
Wizard
Expert Mode
Media-Replay

Partition Name	Number	MPEG-4 Quality	Type	Size (MByte)
Partition 1	01	high quality (CIF) MPEG-4	Ring mode	927

Storage media information

Storage media total size: 927.0 MByte[s]

Number of partitions: 1 of 8 partitions created

Media size used in partitions: 927.0 MByte[s]

Storage media free size: 0 MByte[s]

Recorder on Partition 1 active. Change partition settings not allowed!

MPEG-4
 Not used

[Help on this page?](#)

The storage medium of the VideoJet 10 can handle up to 8 partitions, configured in the same way a typical hard disk for a computer is.

If permanent storage of video sequences on the storage medium is necessary the setup of more than one partition is crucial because after recording of the regarding sequences another partition can be activated to eliminate any possibility of overwriting.

With each partition the parameters can be individually defined in ways like size, quality, type of video recording and compression standard. Changes in these parameters result in a complete reorganization and as a result previously saved data on the partition will be deleted.

All the partitions can be viewed in the table on the page **Media partition** listed by name, order number, recording format/video quality, recording type and partition size.

This page also provides a complete overview of the storage medium information. It provides the total size of the memory, total number of partitions, how much space has been used for partitions, and the size of idle memory in MBytes.

A pie chart is provided giving a visual graphic of how the memory has been allocated.



Note

You can only activate one partition on the hard disk at a time for recording.

Activation of another partition is not automatic, it must be done manually.

 Click on the button **Add partition** to start the wizard.

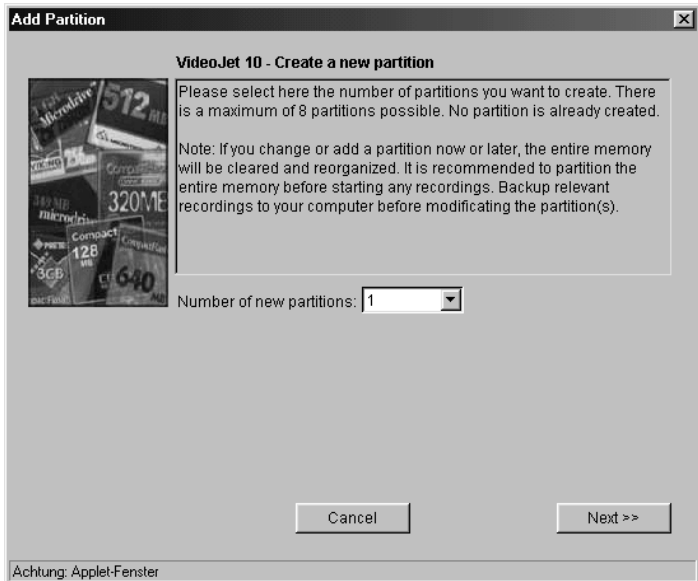

General procedures

Once the wizard is started you will see a new pop-up window appear. In this window you will get information and make the choices as to how the new partition should be configured.

- ☞ Always read the information listed at the top of the window before making your choices.
- ☞ Click on the text field to insert values or use other available controls as buttons, scrollbars or check boxes.
- ☞ Once you have made your choice click the **Next >>** button to go to the next page.
- ☞ Click the **<< Back** button to return and view the previous page.
- ☞ Click on the **Cancel** button to end the wizard without accepting the changes.

Add new partition
✖

VideoJet 10 - Partition size



Select here the number of recordable alarms. Enter a pre-alarm and post-alarm time. Then either choose the recording time or enter a size value in MByte. The missing value will be calculated automatically. By choosing 'Use all', the entire memory left is assigned to this partition.

Number of alarms:

Alarm recording: Pre-alarm Post-alarm

Video recording time:

Partition size: MByte

Use remaining size: Use all

Available capacity: 109 MByte

<< Back
Cancel
Finish

Achtung: Applet-Fenster

Making changes

To activate the changes made with the wizard you have to click the **Finish** button on the last page.

If you click the **Cancel** button the previous settings will remain unaffected.



Attention!

Complete the wizard to the last page. Only then you have the possibility to save all the changes that have been made on previous pages by clicking the **Finish** button at the end.



Note

For every partition that is created on the storage medium the wizard must be completed from beginning to end.

Therefore after starting the wizard you are asked for the total number of partitions you want to install. The wizard will be restarted automatically until all partitions are configured.

Parameters

For each partition a variety of parameters can be chosen.

Partition name:

Input the chosen name for your partition. When creating more than one partition it would be helpful to choose a unique name that will help you in finding specific recordings later.

Video quality:

First select the encoder of which you want to record the data. Then choose the desired video quality. For each encoder the predefined profiles set on the **MPEG-4 Encoder configuration** page are provided.

Recording type:

Choose here in which mode the recordings will be saved on the partition.

Linear mode:

The recordings will be saved to the partition as planned in the recording scheduler. However once the maximum storing capacity has been met for the partition the recording process will stop. In that case further recording on this partition is only possible if the partition is reorganised.

Ring mode:

In Ring mode the newest recordings are recorded over the oldest recordings once the maximum storage capacity has been achieved. E.g. if the maximum storage capacity of the partition allows for a recording of 24 hours to be saved the recordings will then run in a continuous 24 hour loop. Only the last 24 hours of recordings will be able to be viewed.

Partition size:

Select first how many alarms are to be recorded on the partition (max. 128) and the alarm pre- and post-recording time lengths.

Then you can select the partition size either by choosing how long of a recording time you require or by setting the amount of MBytes you would like to use in this partition - in both cases the missing value will automatically be set.

If you have chosen to use the entire memory as one partition or you are configuring the last partition you require just click the **Use all** check box. The rest of the storage capacity will then be configured into that partition for use.

**Note**

When dividing the storage medium into the maximum of 8 partitions, then the complete memory should be utilized. Otherwise the remaining space can not be utilized without reorganization of the entire storage medium.

Deleting of partitions

- ☞ Click in the list on the partition you want to delete to mark it.
- ☞ Click on the button **Delete partition**.
- ☞ Save the changes you have made by clicking the **Set** button.

Changing the configuration

The configuration of the partitions can be changed any time. The parameters of the respective partition are accessed via the **Partition Properties** window.

- ☞ Double click in the list on the partition you wish to make changes to. This will open the **Partition Properties** window with the information on the partition selected.
 - ☞ Make the necessary changes.
 - ☞ Save the changes you have made by clicking the **Set** button
- or
- ☞ Stop any changes from being activated by clicking on the **Cancel** button.

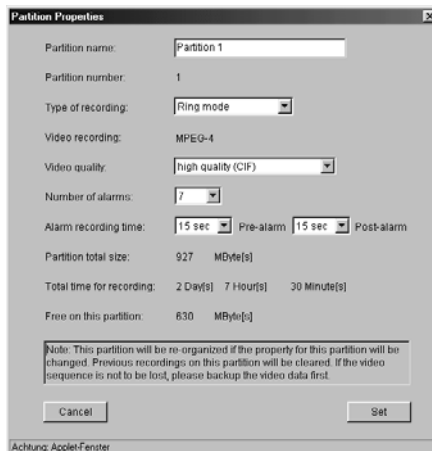



Warning!

Any changes made on a partition will result in a complete reorganization of that partition and all previously saved recordings will be deleted.

Before making any changes to a partition first check to see if any important information has been previously saved to it and make a back-up recording of those sequences to the hard disk of your computer.

The complete recording time, the partition size and the total number of partitions can only be changed using the wizard.



Warning!

Changes to the size or number of partitions will result in a reorganization of the complete storage medium and the deletion of all saved information thereon.

Before any changes a check should be made for important information saved to the memory and if necessary a backup of the regarding sequences should be made to the local hard disk of your computer.

Recording scheduler

Partition selection: Partition 1 [Stop] [Start]

Time recording: Alarm recording Properties

0:00 3:00 6:00 9:00 12:00 15:00 18:00 21:00 24:00

Day	Recording Periods
Monday	
Tuesday	6:00 - 9:00
Wednesday	
Thursday	12:00 - 15:00
Friday	15:00 - 18:00
Saturday	
Sunday	

00:00:00 [Select all] [Clear] [Set]

Recording active

Help on this page?

Here you setup the parameters for local recording onto the storage medium. Recordings can be predefined to take place uninterruptedly over specified periods or only in case of an alarm.

Partition selection:

First choose the partition that shall be active, i.e. on which the recordings shall be stored. Once you have completed setting your recording times this partition can then be activated by clicking on the **Start** button.



Note

You can only activate one partition at a time.

Switching to another partition automatically is not possible. The activation of another partition must be made manually.

Time recording:

This is where the periods will be set for the continuous recordings to the partition. To do so mark one or more time slots for each day by dragging with the depressed mouse button. By clicking into the cells of the top line the period is marked for all days at once.

You can mark the entire week with one click on the **Select all** button. By clicking on the **Clear** button all previously set time slots will be cancelled, clicking on the **Set** button will transmit the data to the VideoJet 10.

Alarm recording:

This is where you program the time spans where the alarm triggered recordings will be active.

The VideoJet 10 disposes of a special recording mode for alarm recording to optimize storage capacity utilization: with the beginning of a respective time slot continuous recording starts on a segment the size of a complete alarm sequence (pre- and post-alarm). This segment on the partition works like a ring buffer and is overwritten again and again until an alarm is actually triggered. After that recording on this segment will go on for the time predefined for post-alarm recording and then a new segment will be used in the same way.

For this reason the recorded alarm file is always complete in length when saved to the partition and the recording space necessary for each alarm recording can be calculated easily. A partition can record up to 128 alarm activations; when the partition is in ring mode it will always contain the most recent alarm recordings in the predefined number.



Note

When the time slots for time recording and alarm recording overlap each other the time recording schedule will always take priority.

Alarm activations that occurred during time recording are specially marked on the playback bar for easy identification when playing back recorded sequences.

Properties:

For a quick overview you have access to the properties of the active partition directly from the recording scheduler.

Recording active:

This is a quick way to know if currently recording is active. In this case the symbol for the storage medium is animated. If it is not animated no recording is taking place.

Alarm sources

Alarm sources

Video loss alarm:

Unified picture detection:

Motion alarm:

Alarm input 1: Name:

1. SNMP host address:

2. SNMP host address:

[Help on this page?](#)

The possible alarm activators of the VideoJet 10 (alarm input and video signal monitoring) can be configured.

Video loss alarm:

Select here the option **On** if the unit is to activate an alarm when the video signal is interrupted.

Unified picture detection:

The VideoJet 10 can trigger an alarm in case the camera picture shows only little contrasts, e.g. when the lens was sprayed with color or covered. Choose the option **On** to activate this function.

Motion alarm:

Select here the option **On** if the unit is to activate an alarm when the motion alarm is triggered.

The configuration of the motion detector can be done on a separate page (see page).

Alarm input 1:

Select the option **On** here in order to activate the alarming by means of an external alarm sensor.

Additionally, it is also possible to select if the alarm is to be activated by an **Active high** or **Active low** voltage level.

Enter a name for the alarm input into the text field which will be displayed on the Livepage next to the alarm symbol.

Alarm connections

1. SNMP host address:

Using the Simple Network Management Protocol (SNMP) the unit can send alarm notifications to two separate host servers. Enter here the IP address of the first SNMP host server.

2. SNMP host address:

Using the Simple Network Management Protocol (SNMP) the unit can send alarm notifications to two separate host servers. Enter here the IP address of the second SNMP host server.

Livepage Wizard Expert Mode

Alarm connections

Connect on alarm: Off

Number of video receiver address: 1

Alarm IP address: 0.0.0.0

Remote password:

Live video auto-connect: Off

Set

[Help on this page?](#)

Options are provided to specify the behavior of the VideoJet 10 in the event of an alarm.

The VideoJet 10, for example, can establish a connection to a predefined IP address (VideoJet 10 receiver or PC with receiver software) automatically.

Connect on alarm:

Select **On**, to automatically establish a connection to a predefined IP address in the event of an alarm.

With the setting **Follows input**, the VideoJet 10 establishes an automatic connection to a remote location as long as an alarm signal is present at the alarm input.

Number of video receiver address:

The VideoJet 10 can store up to 10 different alarm IP addresses. In case of an alarm a connection will be established with the first address. If it is not possible the next following address will be contacted until a connection can be set up. Select the ranking position of the IP address here.

Alarm IP address:

Enter the IP address here to which a connection is to be established in the event of an alarm.

Remote password:

Enter here the 'user'-password for the remote device if necessary.

Live video auto-connect:

Select the option **On** here if it is required to reestablish a connection to the previously specified IP address after each restart, e.g. after a connection breakdown or network dropout.

Motion detector

Motion detector

Motion detector: On

Local sensitivity: 14

Select sensor field: Select area

Average n (frames): 7

Motion tracking: On

Object min size (n*n blocks): 2

Tracker: [checked]

Alarm indicator: [checked]

Threshold: 13

Defaults

Help on this page?

The VideoJet 10 contains an integrated video sensor, which on the basis of the video processing can register changes in the video signal. These changes are primarily initiated by movement in the field of view of the camera.

The sensitivity of the video sensor can be adjusted, so that an alarm is generated only if a given threshold is exceeded.

In order for the alarm to operate, the following conditions must be fulfilled:

- The motion detection must be activated.
- At least one cell must be activated.

- Individual parameters must be matched to the environmental conditions and to the required responses.
- The sensitivity must be set to a value >0 .



Warning!

Light reflections (e.g. in glass facades), switching on or off of floodlights or light level changes caused by cloud movement in bright daylight can cause undesirable responses from the video sensor and thereby generate false alarms. Carry out a number of tests for different day and night time conditions in order to ensure correct operation of the video sensor.

For surveillance of indoor areas, ensure a constant lighting of the areas during the day and at night.

Uniform surfaces without contrast can trigger false alarms even with uniform lighting.

Motion detector

Select here the option **On** to activate the video sensor.

Select sensor field

The areas of the image to be monitored by the video sensor are selected here. The video frame is subdivided into 396 square cells. Each of these cells can be activated or deactivated. If it is necessary to exclude particular regions of the camera field of view from the monitoring process because of, say, continuous movement (e.g. due tree movement in a wind), the relevant cells can be deactivated.

- ☞ Click on the button **Select area**, to configure the sensor cells. A new window is opened up.
- ☞ If necessary, click on the button **Clear all** first in order to clear the current selection (cells indicated in red).
- ☞ Using the left mouse button click in those cells which are to be activated. Activated cells are indicated in red.
- ☞ If required, click on the button **Select all** to monitor the entire video frame.

- ☞ Using the right mouse button, click on those cells which are to be deactivated. Inactivated cells are indicated in white.
- ☞ Click on the button **Set** to store the configuration.
- ☞ Click on the title bar of the window on the symbol **X** to close the window without storing any of the changes entered.

Local sensitivity

The basic sensitivity of the video sensor can be adapted for the ambient camera conditions.

The sensor reacts to brightness variations in the video image. The darker the observation range, the greater the value that must be selected here.

- ☞ Adjust the sensitivity by moving the slider to the desired setting with the mouse key held down.

Average n [frames]

It is possible to define the number of frames during which a movement is monitored in order to generate an alarm. In this way, it is possible to prevent generating a false alarm, e.g. by a bird flying across the surveillance area.

- ☞ Select the desired value by moving the slider to the desired position with the mouse key held down.

Object min size [n*n blocks]

The number of sensor cells, which a moving object must cover in order to generate an alarm, can be specified. In this way it is possible to prevent too small objects from producing an alarm.

For this, the minimum recommended value is 2 (2 × 2 sensor fields).

- ☞ Select the desired value by moving the slider to the desired position with the mouse key held down.
- ☞ Move the mouse pointer onto the blue line.
- ☞ Holding the left mouse button pressed, move the blue line to the required position.

Motion tracking

For certain applications, it can make sense to generate an alarm only if movement takes place in a particular direction. You can acti-

vate the motion detection and select the direction of movement required to generate an alarm.

- ☞ Select here the option **On**, in order to activate the motion tracking feature of the video sensor.

Alarm indicator

To prevent false alarms, a motion signal can be matched to a given alarm threshold. In this way, for example, it is possible to filter out effects caused by the background noise generated in the camera itself.

The blue line indicates the alarm threshold. Any value greater than this will produce an alarm signal. The components of the motion signal generating the alarm are indicated in red. The alarm threshold can be varied to suit individual requirements.

- ☞ Take note of the amplitude of the movement signal displayed in the window over a long period and at all light levels likely to be encountered in practice.

Tracker

In the **Tracker** field you see an arrow, which indicates the current motion in the video image. By means of check boxes in the four corners, the desired direction can be activated. If, for example, all movements to the “left” and “upwards” are to activate an alarm, then mark the top left corner. If all movement to the “left” is to activate the alarm, then check the left upper and the lower left corners.

- ☞ Note the movements indicated by the arrow in the video image over a long period and at all light levels likely to be encountered in practice.
- ☞ Click the check box in order to activate the corresponding directional component.

Relay configuration

Livepage	Wizard	Expert Mode
Relay action		
Idle state:	<input type="text" value="Open"/>	
Operating mode:	<input type="text" value="Bistable"/>	
Relay follows:	<input type="text" value="Off"/>	
Relay name:	<input type="text" value="Relay"/>	<input type="button" value="Set"/>
Relay operation		
Trigger relay:	<input type="button" value="Relay"/>	
Help on this page?		

The switching conditions for the relay output can be configured. The function of an open switching relay (normally closed contact) or a closed switching relay (normally open contact) can be specified.

It is also possible to specify whether the output should operate as a bistable or as a monostable. In bistable operation, the activated state of the relay remains as switched. In monostable operation, the time can be selected after which the relay is to revert to its steady state.

Various events can be selected to automatically activate the output. In this way, for example, it is possible to switch on a floodlight when a motion alarm has been detected and to switch the light off again at the end of the alarm.

Idle state:

Select **Open** if the relay is to operate as a normally open contact or **Closed** if it is to operate as a normally closed contact.

Operating mode:

Select the operating mode for the relay.

If, for example, a lamp is switched on by an alarm and is to remain on when the alarm has ended, select **Bistable**. If an acoustic signal activated by an alarm is to remain on for a period of, for example, 10 sec, select **10s**.

Relay follows:

Select a particular event by which the relay is to be activated as required. The following events can activate the relay:

- **Off:** No relay triggering by events
- **Connection:** Triggering if any connection is established
- **Video alarm:** Triggering caused by loss of the video signal
- **Motion alarm:** Triggering by the motion alarm
- **Local input:** Triggering caused by an external alarm sensor
- **Remote input:** Triggering by a switching contact from a remote location (only when a connection is established)
- **Unified picture alarm:** Triggering caused by lack of contrast in the picture

Relay name:

The relay can be assigned a name from here. The name will be shown on the Livepage, depending upon configuration.

Trigger relay:

Click on the button to manually switch the relay (e.g. for test purposes or to operate a door opener).

Interface COM 1

Livepage	Wizard	Expert Mode
COM1 serial data port		
Serial port function:	Terminal	Set
COM1 interface settings		
Baud rate:	19200	
Data bits:	8	
Stop bits:	1	
Parity check:	None	
Interface mode:	RS232	
Half-duplex mode:	Off	Set

[Help on this page?](#)

The parameters for the serial interface port **COM1: RS232/485** can be configured to suit individual requirements.

Serial port function:

Select one of the controllable devices from the list. If the port is required to transmit transparent data, select the entry **Transparent**.



Note

After selecting a device, the remaining parameters in the window are automatically set and should not be altered.

Baud rate:

Select the value for the transmission rate in Bit/s.

Data bits:

The number of data bits cannot be changed.

Stop bits:

Select the number of stop bits per character.

Parity check:

Select the type of parity check.

Interface mode:

Select the desired protocol for the serial port.

Half-duplex mode:

Select here the mode to suit the individual application.

Interface COM 2

COM2 serial data port

Serial port function: Terminal

COM2 interface settings

Baud rate: 19200

Data bits: 8

Stop bits: 1

Parity check: None

[Help on this page?](#)

The parameters for the serial interface port **COM2: RS232** can be configured to suit individual requirements.

Serial port function:

Select the function for serial port 2. Select **Terminal** if the unit is to be operated from a terminal. If the port is required to transmit transparent data, select the entry **Transparent**.

Baud rate:

Select the value for the transmission rate in Bit/s.

Data bits:

The number of data bits cannot be changed.

Stop bits:

Select the number of stop bits per character.

Parity check:

Select the type of parity check.

Network settings

page	Wizard	Expert Mode	Media-Reply
Network settings			
Unit IP address:	<input type="text" value="10.0.16.88"/>		
Subnet mask:	<input type="text" value="255.0.0.0"/>		
Gateway address use for:	<input type="text" value="LAN"/>		
Gateway IP address:	<input type="text" value="0.0.0.0"/>	Reboot after 'Set' necessary!	
Video/Audio transmission:	<input type="text" value="UDP"/>		
Ethernet link type:	<input type="text" value="Auto"/>		
DNS server IP address:	<input type="text" value="195.145.107.78"/>		
DNS refresh time:	<input type="text" value="30"/>	(Between 30 - 86400 sec.)	<input type="button" value="Set"/>

[Help on this page?](#)

The settings on this page are used to integrate the unit into an existing network.



Warning!

Changes in IP address, subnet mask and/or gateway IP address are transferred to the device by clicking on the button **Set**, but they are only valid after a reboot!

For a reboot simply enter the old IP address into the address bar of the Browser followed by `/reset`, after that the unit can only be accessed via the new IP address.

Unit IP address:

Enter the required IP address for the VideoJet 10 here. The IP address must be valid for the network.

Subnet mask:

Enter the corresponding subnet address here if the unit is to communicate via a subnet.

Gateway address use for:

Choose here for which network adapter the gateway should be used.

Gateway IP address:

Enter the appropriate IP address here if the unit is to independently establish a connection outside of the local network. This field can otherwise remain empty (0.0.0.0).

Video/Audio transmission:

If the device is used in front of a firewall, transmission over **TCP (Port 80)** should be selected. If used in a local network select **UDP**.

**Warning!**

Multicast operation is only possible using the UDP protocol. The TCP protocol does not support any multicast connection.

Ethernet link type:

Adjust here the ethernet link to the network. In most applications 'Auto' is the correct choice. For some routers and switches it can be necessary to set the Ethernet link to a fixed value. In that case select the appropriate value:

- 10 MBit/s HD = 10 MBit/s half-duplex
- 10 MBit/s FD = 10 MBit/s full-duplex
- 100 MBit/s HD = 100 MBit/s half-duplex
- 100 MBit/s FD = 100 MBit/s full-duplex

DNS Server IP address:

Working with a device over the Internet dynamic IP addresses are assigned for efficient use of the IP address pool, i.e. the device gets a new (changing) IP address each time a connection is set up.

Connecting is easier when the device is listed on a DNS server. The device logs in regularly leaving the device name, device IP address and the current Internet IP address. To connect to a device over the Internet you just insert the device name together with the URL of the DNS server which then returns the valid Internet IP address for automatic connection set up.

The default setting for the DNS server IP address is the IP address of the DNS server videotec.info. The VideoJet 10 contacts the server automatically when a refresh time is specified in the next

parameter. If e.g. the name of the VideoJet 10 is 'myVideoJet' just type myVideoJet.videotec.info as URL to set up a connection.



Note

Assign a unique name to the VideoJet 10 if you want to use this feature.

DNS refresh time:

Enter here the time interval for the VideoJet 10 to contact the DNS server. You can enter a value from 30 to 86400 sec (24 h). Leave this field empty when you don't want to use the DNS function.

Wireless LAN

Livepage	Wizard	Expert Mode	Media-Replay
Wireless LAN configuration			
WLAN IP address:	<input type="text" value="10.0.14.19"/>		
WLAN subnet address:	<input type="text" value="255.255.255.0"/>		
Network name:	<input type="text" value="Default_SSID"/>		
WLAN port type:	<input type="text" value="BSS (infrastructure mode)"/>		
Channel settings:	<input type="text" value="Default Channel"/>		
Access point density:	<input type="text" value="Low"/>		
WLAN Encryption:	<input type="button" value="Encryption"/>	<input type="button" value="Set"/>	
Wireless LAN link status			
Connection State:	No WLAN adapter found!		
Current transmission rate:			
Link quality:	<input type="text" value="0 %"/>		
Help on this page?			

Apart from the integrated Ethernet adapter of the VideoJet 10 a suitable Wireless LAN adapter card can be inserted at the Compact-Flash slot of the device. Thus the VideoJet 10 can be easily integrated into an existing Wireless LAN, without the need of additional wiring of CAT.5 network cables.

**Warning!**

When setting up a Wireless LAN take account of the technical information of all devices, e.g. Access Points or WLAN cards.

WLAN IP address:

For connection via Wireless LAN a dedicated Wireless LAN IP address must be assigned to the VideoJet 10. This IP address must refer to a subnet other than the Ethernet IP address.

Enter here the IP address for the Wireless LAN.

WLAN subnet address:

Enter here the subnet address referring to the WLAN IP address.

Network name:

In order of two devices being connected over WLAN they must belong to the same WLAN.

Enter here the name of the desired Wireless LAN.

WLAN port type:

Here you decide on the port type used for the Wireless LAN connection:

- 'BSS (Infrastructure mode)': Connection via Access Point
- 'IBSS (Peer-to-peer mode)': Direct connection to another WLAN capable device, e.g. laptop or VideoJet device

Channel settings:

Choose here the channel for the WLAN connection.

**Warning!**

Transmitter and receiver must use the same channel to enable transmission.

Access point density:

Enter here a value indicating the number of available Access Points. Choose 'High' if the number is large, 'Low' if only a few Access Points are available.

WLAN encryption:

WLAN connections are not protected against unauthorized access. It is possible to code the data with an encryption key for security.

 Click on the button 'Encryption' to open the respective window.

Channel Encryption:

You can choose out of four settings with different security levels:

- 'No Encryption' means the data is not protected with an encryption key. A connection is only set up when the encryption functionality on the remote device is disabled, too.
- 'Open System' means the encryption used is depending on the settings of the remote device. If the remote device operates with an encryption key, the local unit must have the same key for communication. When the remote device operates without an encryption key no WEP keys are required on this device.
- 'Shared Key' stands for permanent WLAN standard encryption. Encryption keys of 40 or 104 Bits of length are used in this mode. Remote and local device must use identical keys to enable transmission.
- 'Shared Key 128' stands for permanent encryption with 128 Bits for the Wireless LAN connection. This mode is only possible when a Prism II chipset is used on both devices connected. This mode does not correspond to a Wireless LAN standard mode.

WEP key index:

When encryption is activated on both ends of the WLAN connection the same WEP key index must be used to enable transmission.

WEP key 1-4:

Enter here the four keys if you want to protect the connection. The keys can be entered as standard text in ASCII format or as hexadecimal value. Standard text can be 5 or 13 Bytes of length for 'Shared Key' and 16 Bytes for 'Shared Key 128'. When entering hexadecimal digits the key can be 10 or 26 Bytes of length for

'Shared Key' and 16 Bytes for 'Shared Key 128' (sample for hexadecimal WEP key with the length 10: FFFBEEEE12A). All four keys must have the same length.

**Warning!**

Connection is only possible when both ends use the same encryption parameters.

Connection state:

Here the connection state of the WLAN adapter is displayed. The following messages are possible:

- 'No WLAN adapter found'
- 'Connecting! Try to establish connection'
- 'Connection successfully established' with a data rate of 11, 5.5, 1 or 2 MBit

Current transmission rate:

This text message box informs about the current transmission rate from the local Wireless LAN adapter to the remote device.

**Warning!**

Wireless LANs do not guarantee a specific data rate, as it depends on the intensity of the destination field. The de facto data rate is conditioned by the weakest link within the WLAN.

Link quality:

The value indicates the quality of the current Wireless LAN connection. A value of 100% stands for best link quality to the next Access Point or remote device. A value less than 15% indicates very poor quality at a critical limit.

Multicast settings

Livepage	Wizard	Expert Mode
Multicast settings		
Multicast streaming:	<input type="text" value="Off"/>	
Multicast group IP address:	<input type="text" value="224.1.1.129"/>	
Multicast video port encoder 1:	<input type="text" value="60000"/>	
Multicast video port encoder 2:	<input type="text" value="61000"/>	
Multicast audio port:	<input type="text" value="55000"/>	
Multicast packet TTL:	<input type="text" value="1"/>	<input type="button" value="Set"/>

[Help on this page?](#)

Multicast streaming:

Along with a 1:1 connection between a transmitter and a receiver, (unicast) the VideoJet 10 provides the option of connecting a number of receivers to simultaneously receive the video signal. This is achieved either by a duplication of the data stream in the unit with subsequent distribution to a number of receivers (multi-unicast) or by distribution of a single data stream on the network itself to a number of receivers in a defined group (multicast).

Select here the option **On** in order to activate the multicast function.



Note

Requirement for multicast operation is a multicast compliant network with implementation of the UDP protocol and the IGMP protocol. Other group membership (management) protocols are not supported. The TCP protocol does not support any multicast connection.

The VideoJet 10 supports the multi-unicast operation for up to 5 simultaneously connected receivers.

The transparent data connection is maintained from the first unit. However, after approx. 5 seconds of inactivity the data connection is automatically suspended and another unit can exchange transparent data with the transmitter. The audio channel is maintained by the first receiver to set up the connection and only available when that connection is terminated.

For multilink operation, the network is not required to be multicast compatible as the VideoJet 10 is also multi-unicast compatible.

Duplication of the data in the unit requires considerable processor power and, under certain circumstances, leads to limitations in the picture quality.

With the settings **Multicast streaming: On** and **Multicast group IP address: 0.0.0.0** the VideoJet 10 operates in the multi-unicast mode (duplication of the data stream in the unit).

With the settings **Multicast streaming: On** and a valid multicast group IP address, the unit operates in the multicast mode (duplication of the data stream over the network).

Multicast group IP address:

A precondition for the multicast mode in a multicast-compatible network is the establishment of a special IP address (class D address).

The network must support the establishment of a group IP address and the Internet Group Membership(management) Protocol (IGMP). The address range is from 224.0.1.0 to 238.255.255.255.

Multicast video port encoder 1:

With dual encoding, the two data streams must be assigned for different ports.

Enter here the port address for the data stream of encoder 1.

Multicast video port encoder 2:

With dual encoding, the two data streams must be assigned for different ports.

Enter here the port address for the data stream of encoder 2.

Multicast audio port:

In MPEG-4 format, the streams for video and audio are transmitted over separate ports. If you want to transmit MPEG-4 with audio you must assign a dedicated audio port.

Enter here the port address for the audio stream.



Note

For MPEG-4 audio transmission the option **Activate audio** in the **Audio configuration** must be activated (see page 46).

Multicast packet TTL:

By setting the parameter you determine the life span of the data packets in the network. If multicast is operated over a router the value must be greater than 1 to guarantee transmission of the packets.

Version information

Livepage	Wizard	Expert Mode
Version information		
Hardware version:	<input type="text" value="B0005A41"/>	
Software version:	<input type="text" value="14000105"/>	

[Help on this page?](#)

Hardware and software version numbers are only required for information and cannot be altered. Keep a record of these numbers in case technical assistance is required.

Hardware version:

The hardware version number of the VideoJet 10 is shown.

Software version:

The software version number of the VideoJet 10 is shown.

Livepage settings

Livepage	Wizard	Expert Mode
Livepage configuration		
Startpage background URL:	<input type="text" value="VCS default"/>	<input type="button" value="Search"/>
Startpage logo URL:	<input type="text" value="VCS default"/>	<input type="button" value="Search"/>
Video from Encoder on live page:	<input checked="" type="radio"/> MPEG-4 Encoder 1 <input type="radio"/> MPEG-4 Encoder 2	
Alarm input on livepage:	<input checked="" type="checkbox"/> Show alarm	
Relay output on livepage:	<input checked="" type="checkbox"/> Show relay	
Event messages on livepage:	<input checked="" type="checkbox"/> Show event messages	
Show general messages on livepage:	<input checked="" type="checkbox"/> Show general messages	
Panorama (Sony camera only):	<input type="checkbox"/> Show panorama view	
Save event logfile to harddisk:	<input checked="" type="checkbox"/> Save event file	
Save general logfile to harddisk:	<input checked="" type="checkbox"/> Save general file	
File for saving event messages:	<input type="text" value="C:\Event.txt"/>	<input type="button" value="Search"/>
File for saving general messages:	<input type="text" value="C:\General.txt"/>	<input type="button" value="Search"/>
Path for JPEG and MPEG files:	<input type="text" value="C:\"/>	<input type="button" value="Search"/> <input type="button" value="Set"/>

Help on this page?

The Livepage can be setup to suit individual requirements. Options are provided here to display different information and operating elements along with the video picture.

In addition, individual background images for the main window and for the upper screen area (banner) can be used.



Note

For the background image you can use the file types GIF and JPEG. The file paths must correspond to the type of access (for access to a locally stored file, for example, C:\Images\Logo.gif, for access to an Internet/Intranet file, for example, http://www.sld.co.uk/images/logo.gif).

Note that with Internet/Intranet access, the connection must be maintained in order to continually display the image. The image files are not stored in the VideoJet 10.

- ☞ Click in the check boxes of those elements which are to be displayed on the Livepage. The selected elements are marked with a tick.
- ☞ Check on the Livepage to see if and how the required elements are displayed.

Startpage background URL:

Enter the file path to a suitable background image here. The image can be stored on a local computer, on a local network or at an Internet address.

- ☞ If necessary, click on the button **Search**, in order to find a suitable image on the local network.

Startpage logo URL:

Enter here the file path to a suitable image for the upper screen area (banner). The image can be stored on a local computer, on a local network or at an Internet address.

- ☞ If necessary, click on the button **Search**, in order to find a suitable image on the local network.



Note

If it is required to recall the original image, simply delete the entries in the fields **Startpage background URL** and **Startpage logo URL**.

Video from Encoder on live page:

Choose here which encoder is to be the source of the video stream on the Livepage.

Panorama (Sony camera only):

If you are using a Sony camera EVI-D100 or EVI-D30/31 by clicking into this check box you can activate the display of a panorama on the Livepage that is generated automatically each time the Livepage is called up and that can be updated any time (see page 106).

Save event logfile to harddisk:

Select this option to store event data in a text file on the local computer.

These text files can be viewed in the usual Office programs (for example, MS Word or MS Excel), and printed out.

Save general logfile to harddisk:

Select this option to store the general logfile in a text file on the local computer.

These text files can be viewed in the usual Office programs (for example, MS Word or MS Excel), and printed out.

File for saving event messages:

Enter here the path to the location where the log files for the event messages are to be stored.

- ☞ If necessary, click on the button **Search** in order to find a suitable folder.

File for saving general messages:

Enter here the path to the location where the log files for the general system messages are to be stored.

- ☞ If necessary, click on the button **Search** in order to find a suitable folder.

Path for JPEG an MPEG files:

Enter the path to the storage location for the individual images and MPEG recordings which can be stored from the Livepage here.

- ☞ If necessary, click on the button **Search** in order to find a suitable folder.

Software update

Livepage	Wizard	Expert Mode
Software update		
Software upload:	<input type="text"/>	<input type="button" value="Durchsuchen..."/> <input type="button" value="Upload"/>
Upload progress:	<input type="text" value="0%"/>	
Configuration download:		<input type="button" value="Download"/>
Configuration upload:	<input type="text"/>	<input type="button" value="Durchsuchen..."/> <input type="button" value="Upload"/>

[Help on this page?](#)

Software upload:

The VideoJet 10 is designed in such a way that its functions and parameters can be updated with firmware. In such cases, transmit the updated firmware package via the selected network to the device. On termination of the connection, the firmware will be automatically installed.

This allows a device to be remotely serviced and updated without a technician having to modify the device installation on site.



The latest firmware can be obtained from your Service centre



Warning!

Before starting the firmware upload, ensure that you have selected the correct upload file! An upload of other files can result in the device being no longer addressable and having to be replaced.

On no account interrupt the installation of the firmware. An interruption will result in damage to the flash EPROM. This can result in the device being no longer addressable and having to be replaced.

-
-  First, store the update files to the hard disk.
 -  Enter the complete directory path for the update file in the text field or click on the button **Durchsuchen...** to locate and select the file.
 -  Click on the button **Upload** to begin the transmission to the unit. The progress of the download can be monitored from the status messages and from the progress bar.

On completion of a successful upload, the unit will automatically restart.

If the LED **Power** flashes red and green alternately, the upload has been unsuccessful and must be restarted. In order to perform the upload, it is necessary to change over to a special page:

- ☞ Enter `/main.htm` in (e.g. `192.168.0.12/main.htm`) in the address field of the browser behind the IP address of the unit.
- ☞ Restart the upload process.

Configuration download:

You can store the configuration setting of the device on a PC.

- ☞ Click on the button **Download**. A dialog window is opened.
- ☞ Follow the instructions in the dialog window to save the settings.

Configuration upload:

You can upload stored configuration settings from a PC.

- ☞ Enter the complete directory path of the file to be uploaded or click on the button **Durchsuchen...** to select the desired file.
- ☞ Ensure that the download file originates from the same type of device that you want to reconfigure.
- ☞ Click on the button **Upload** to start the transmission of the file to the device.

After a few seconds the message **Configuration upload finished. State: Configuration upload ok. (system must be rebooted)** will be displayed and the countdown for the reconnection is shown.

- ☞ Restart the device.

At the next call-up of the configuration page **Software update** the message **Configuration upload ok** confirms the successful completion of the upload. If the message **Configuration upload failed** is displayed the file was not correctly uploaded (e.g. because it did not originate from the same type of device). Repeat the upload procedure, possibly with a different file.

VideoJet 10 receiver

On the Decode connection page you can select the required installation mode on the menu line:



Installation Wizard

The Installation Wizard of the VideoJet 10 guides you step by step through the necessary procedures.

Wizard start-up

The wizard can be started by clicking on the link **Installation Wizard** on the start page.

- ☞ On the installation wizard field click on the button with the wizard symbol. The wizard window will open up.
- ☞ Click on the button **Start** to call up the wizard.

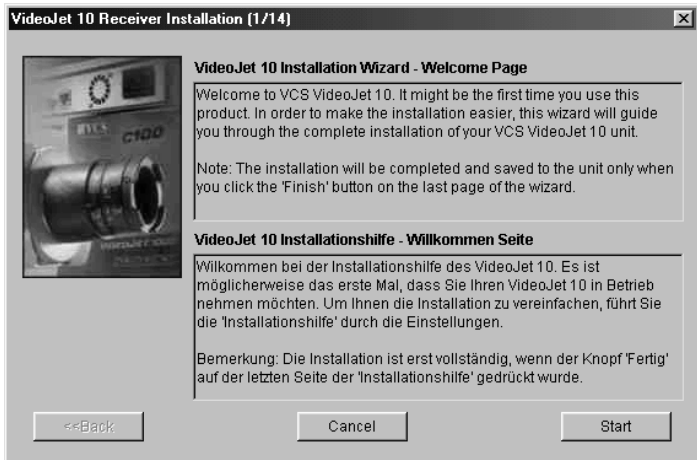

General procedures

When the Installation Wizard has been started, a new window will open up which contains information and in which settings can be made.

- ☞ Always read the information in the upper section of the window first.
- ☞ Click in the text boxes to enter values or else use the other elements which are available such as buttons, check boxes or list fields.
- ☞ Click on the button **Next >>** to continue to the next stage.
- ☞ To return to a previous screen to check a previous setting click on the button **<< Back**.
- ☞ Click on the button **Cancel**, to interrupt the process and close the installation wizard.



Store changes

Changes called up in the installation wizard are only effective when the button **Finish** on the last page is clicked.

The original settings are retained if the button **Cancel** is clicked.



Warning!

Carry on with the installation wizard to the final screen if possible. This is the only location where all of the changes made can be stored by clicking on the button **Finish**.

Expert Mode

In the Expert Mode, all parameters of the VideoJet 10 can be configured. If any of the configuration pages are called up, the current settings will be displayed. The settings can be altered by entering new values or by selecting from a predefined value in a list field.

Navigation

The Expert Mode is selected by clicking on the link **Expert Mode** in the menu line.



Click on one of the links on the left border of the window. The corresponding page will be opened up.



Store changes

If any of the configuration pages is called up, the current settings will be displayed. The settings can be altered by entering new values or by selecting from a predefined value in a list field. When a change has been entered, click on the associated button **Set** in order to store the change.



Warning!

Store all changes with the associated button **Set**. By clicking on the button **Set** only the changes in the relevant field are stored (blue frame). Changes in any of the other fields are ignored.

Unit identification

coder connection	Installation Wizard	Expert Mode
Unit identification		
Unit name:	<input type="text"/>	
Unit ID:	<input type="text"/>	<input type="button" value="Set"/>
Help on this page?		

Unit name:

Enter a name for the unit here. This name will be displayed in the video image, depending on the configuration.

Unit ID:

Each VideoJet 10 should be assigned a unique identifier which can additionally be used to identify the unit.

Password settings



The screenshot shows a web browser window with a dark header bar containing the text "coder connection", "Installation Wizard", and "Expert Mode". Below the header is a white box titled "Password settings". Inside this box, there are three input fields: "User name:" with a dropdown arrow, "Password:" with a text box, and "Password confirm:" with a text box. To the right of the "Password confirm:" field is a grey button labeled "Set". Below the white box is a link that says "Help on this page?"

User name:

The access to a VideoJet 10 is generally protected with a password in order to prevent unauthorised use of the device. The receivers operate with two authorisation levels: **service** and **user**.

In the authorisation level **service**, you can change all the configuration settings after entering the corresponding password.

With the authorisation level **user** you can operate but not configure the device. You can have a live picture or the configuration settings displayed, but you cannot change them.

Password:

You can define and change passwords for access to the device when you are working with the authorisation level 'service' or if the device is not protected with a password. You can change only one of the two passwords at a time. In order to change the password of another level, you have to call up this configuration page again.

Password confirm:

Enter the new password again to rule out the risk of typing errors.

Language selection



The screenshot shows a web browser window with a dark header bar containing the text "coder connection", "Installation Wizard", and "Expert Mode". Below the header is a white box titled "Language selection". Inside this box, there is one input field: "Website language:" with a dropdown menu showing "English". To the right of the dropdown is a grey button labeled "Set". Below the white box is a link that says "Help on this page?"

Website language:

Here you select the desired language of the HTML pages.

Date and time

The screenshot shows a web browser interface for the 'Installation Wizard'. At the top, there are three tabs: 'encoder connection', 'Installation Wizard' (which is active), and 'Expert Mode'. Below the tabs is a section titled 'Date and time'. This section contains three rows of input fields:

- 'Date format:' with a dropdown menu currently set to 'Europe'.
- 'Unit date:' with three input boxes containing 'Friday', '05', and '12', followed by a period and a box containing '2003'.
- 'Unit time:' with three input boxes containing '05', '27', and '07', followed by a 'Synchr. PC' button and a 'Set' button.

 Below the form, there is a small link that says 'Help on this page?'.

If a number of VideoJet units are combined in a system, it is important that the internal clocks of the separate units are all synchronized. Only if all units operate with the same time it is possible, for example, to correctly identify and evaluate events which have occurred simultaneously.

Date format:

Select the desired date format here

(Europe: DD.MM.YYYY; USA: MM.DD.YYYY, Japan: YYYY/MM/DD).

Unit date:

Enter the current date here. As the system time is driven by the internal calendar clock, it is not necessary to enter the day of week. This is automatically appended.

Unit time:

Enter the current time here or click on the button **Synchr. PC**, in order to transfer the system time of the computer to the unit.

Timer server

coder connection Installation Wizard Expert Mode

Timer server

Time zone:	<input type="text" value="(UTC -12:00) Dateline Std. Time"/>	
Time server IP address:	<input type="text" value="0.0.0.0"/>	<input type="button" value="Set"/>

[Help on this page?](#)

The VideoJet 10 can receive a time signal from a TIME server (NTP server) and use it to set the internal clock. The device calls up the time signal automatically every two hours.

Time zone:

Here you select the current time zone.

Time server IP address:

Enter the IP address of a TIME server here.

Monitor settings

coder connection Installation Wizard Expert Mode

Monitor settings

Video monitor name:	<input type="text"/>	
Video output standard:	<input type="text" value="NTSC"/>	<input type="button" value="Set"/>

[Help on this page?](#)

Video monitor name:

Enter the desired monitor name here. The monitor name is used for easier remote identification of the monitor location. Enter here an unambiguous and clear name.

Video output standard:

Choose here the correct output standard in dependence of the monitor used.



Warning!

Ensure to set the correct video norm in order to avoid damages to the monitor.

Audio configuration

The screenshot shows the 'Audio configuration' section of a web browser interface. At the top, there are three tabs: 'encoder connection', 'Installation Wizard', and 'Expert Mode'. The 'Installation Wizard' tab is active. Below the tabs, the title 'Audio configuration' is displayed. The main content area contains a form with the label 'Activate audio:' followed by a dropdown menu currently set to 'Off'. To the right of the dropdown is a 'Set' button. Below the form, there is a link that says 'Help on this page?'.

Activate audio:

Decide here if you want to receive an audio stream along with the MPEG-4 video. Transmission of audio requires additional bandwidth of approx. 80 kBit/s.



Note

Ensure that audio is activated in the transmitter audio configuration, too (see page 46).

Alarm sources

The screenshot shows the 'Alarm sources' section of a web browser interface. At the top, there are three tabs: 'encoder connection', 'Installation Wizard', and 'Expert Mode'. The 'Installation Wizard' tab is active. Below the tabs, the title 'Alarm sources' is displayed. The main content area contains a form with the label 'Alarm input 1:'. This label is followed by a dropdown menu set to 'Off', another dropdown menu set to 'Active high', and a text input field for 'Name:'. Below this, there are two rows for 'SNMP host address:'. The first row has an input field containing '0.0.0.0'. The second row also has an input field containing '0.0.0.0'. To the right of the second row is a 'Set' button. Below the form, there is a link that says 'Help on this page?'.

The possible alarm activator of the VideoJet 10 can be configured.

Alarm input 1:

Select the option **On** here in order to activate the alarming by means of an external alarm sensor.

Additionally, it is also possible to select if the alarm is to be activated by an **Active high** or **Active low** voltage level.

Enter a name for the alarm input into the text field.

1. SNMP host address:

Using the Simple Network Management Protocol (SNMP) the unit can send alarm notifications to two separate host servers. Enter here the IP address of the first SNMP host server.

2. SNMP host address:

Using the Simple Network Management Protocol (SNMP) the unit can send alarm notifications to two separate host servers. Enter here the IP address of the second SNMP host server.

Alarm connections

The screenshot shows a web browser interface for configuring alarm connections. At the top, there are three tabs: 'coder connection', 'Installation Wizard', and 'Expert Mode'. The 'Installation Wizard' tab is active. Below the tabs, the title 'Alarm connections' is displayed. The main content area contains several configuration fields: 'Connect on alarm:' with a dropdown menu set to 'Off'; 'Number of video receiver address:' with a dropdown menu set to '1'; 'Alarm IP address:' with a text input field containing '10.0.1.99'; 'Remote password:' with an empty text input field; and 'Live video auto-connect:' with a dropdown menu set to 'On'. A 'Set' button is located at the bottom right of the form.

[Help on this page?](#)

Options are provided to specify the behavior of the VideoJet 10 in the event of an alarm.

The VideoJet 10, for example, can establish a connection to a predefined IP address (VideoJet 10 receiver or PC with receiver software) automatically.

Connect on alarm:

Select **On**, to automatically establish a connection to a predefined IP address in the event of an alarm.

With the setting **Follows input**, the VideoJet 10 establishes an automatic connection to a remote location as long as a signal is present at the alarm input. This setting can also be used to connect two VideoJet 10 units via a control switch. In this case, a computer is not needed to establish the connection.

Number of video receiver address:

The VideoJet 10 can store up to 10 different alarm IP addresses. In case of an alarm a connection will be established with the first address. If it is not possible the next following address will be contacted until a connection can be set up. Select the ranking position of the IP address here.

Alarm IP address:

Enter the IP address here to which a connection is to be established in the event of an alarm.

Remote password:

Enter here the 'user'-password for the remote device if necessary.

Live video auto-connect:

Select the option **On** here if it is required to reestablish a connection to the previously specified IP address after each restart, e.g. after a connection breakdown or network dropout.

Relay configuration

Encoder connection Installation Wizard Expert Mode

Relay action

Idle state:

Operating mode:

Relay follows:

Relay name:

Relay operation

Trigger relay:

[Help on this page?](#)

The switching conditions for the relay output can be configured. The function of an open switching relay (normally closed contact) or a closed switching relay (normally open contact) can be specified.

It is also possible to specify whether the output should operate as a bistable or as a monostable. In bistable operation, the activated state of the relay remains as switched. In monostable operation, the time can be selected after which the relay is to revert to its steady state.

Various events can be selected to automatically activate the output. In this way, for example, it is possible to switch on a floodlight when a motion alarm has been detected and to switch the light off again at the end of the alarm.

Idle state:

Select **Open** if the relay is to operate as a normally open contact or **Closed** if it is to operate as a normally closed contact.

Operating mode:

Select the operating mode for the relay.

If, for example, a lamp is switched on by an alarm and is to remain on when the alarm has ended, select **Bistable**. If an acoustic signal activated by an alarm is to remain on for a period of, for example, 10 sec, select **10s**.

Relay follows:

Select a particular event by which the relay is to be activated as required. The following events can activate the relay:

- **Off:** No relay triggering by events
- **Connection:** Triggering if any connection is established
- **Local input:** Triggering caused by an external alarm sensor
- **Remote input:** Triggering by a switching contact from a remote location (only when the connection is established)

Relay name:

The relay can be assigned a name from here. The name will be shown on the Livepage, depending upon configuration.

Trigger relay:

Click on the button to manually switch the relay (e.g. for test purposes or to operate a door opener).

Interface COM 1

coder connection		Installation Wizard		Expert Mode	
COM1 serial data port					
Serial port function:	Terminal			<input type="button" value="Set"/>	
COM1 interface settings					
Baud rate:	19200				
Data bits:	8				
Stop bits:	1				
Parity check:	None				
Interface mode:	RS232				
Half-duplex mode:	Off			<input type="button" value="Set"/>	
<small>Help on this page?</small>					

The parameters for the serial interface port **COM1: RS232/485** can be configured to suit individual requirements.

Serial port function:

Select one of the controllable devices from the list. If the port is required to transmit transparent data, select the entry **Transparent**.

**Note**

After selecting a device, the remaining parameters in the window are automatically set and should not be altered.

Baud rate:

Select the value for the transmission rate in Bit/s.

Data bits:

The number of data bits cannot be changed.

Stop bits:

Select the number of stop bits per character.

Parity check:

Select the type of parity check.

Interface mode:

Select the desired protocol for the serial port.

Half-duplex mode:

Select here the mode to suit the individual application.

Interface COM 2

ecoder connection Installation Wizard Expert Mode

COM2 serial data port

Serial port function: Terminal Set

COM2 interface settings

Baud rate: 19200

Data bits: 8

Stop bits: 1

Parity check: None Set

[Help on this page?](#)

The parameters for the serial interface port **COM2: RS232** can be configured to suit individual requirements.

Serial port function:

Select the function for serial port 2. Select **Terminal** if the unit is to be operated from a terminal. If the port is required to transmit transparent data, select the entry **Transparent**.

Baud rate:

Select the value for the transmission rate in Bit/s.

Data bits:

The number of data bits cannot be changed.

Stop bits:

Select the number of stop bits per character.

Parity check:

Select the type of parity check.

Network settings

ecoder connection		Installation Wizard		Expert Mode	
Network settings					
Unit IP address:	<input type="text" value="10.0.16.88"/>				
Subnet mask:	<input type="text" value="255.0.0.0"/>				
Gateway address use for:	<input type="text" value="LAN"/>				
Gateway IP address:	<input type="text" value="0.0.0.0"/>	Reboot after 'Set' necessary!			
Video/Audio transmission:	<input type="text" value="UDP"/>				
Ethernet link type:	<input type="text" value="Auto"/>				
DNS server IP address:	<input type="text" value="195.145.107.78"/>				
DNS refresh time:	<input type="text" value="30"/>	(Between 30 - 86400 sec.)		<input type="button" value="Set"/>	
Help on this page?					

The settings on this page are used to integrate the unit into an existing network.



Warning!

Changes in IP address, subnet mask and/or gateway IP address are transferred to the device by clicking on the button **Set**, but they are only valid after a reboot!

For a reboot simply enter the old IP address into the address bar of the Browser followed by `/reset`, after that the unit can only be accessed via the new IP address.

Unit IP address:

Enter the required IP address for the VideoJet 10 here. The IP address must be valid for the network.

Subnet mask:

Enter the corresponding subnet address here if the unit is to communicate via a subnet.

Gateway address use for:

Choose here for which network adapter the gateway should be used.

Gateway IP address:

Enter the appropriate IP address here if the unit is to independently establish a connection outside of the local network. This field can otherwise remain empty (0.0.0.0).

Video/Audio transmission:

If the device is used in front of a firewall, transmission over **TCP (Port 80)** should be selected. If used in a local network select **UDP**.



Note

Ensure that the settings regarding the Video/Audio transmission of the receiver are matching with the transmitter settings.

Ethernet link type:

Adjust here the ethernet link to the network. In most applications 'Auto' is the correct choice. For some routers and switches it can be necessary to set the Ethernet link to a fixed value. In that case select the appropriate value:

- 10 MBit/s HD = 10 MBit/s half-duplex
- 10 MBit/s FD = 10 MBit/s full-duplex
- 100 MBit/s HD = 100 MBit/s half-duplex
- 100 MBit/s FD = 100 MBit/s full-duplex

DNS Server IP address:

Working with a device over the Internet dynamic IP addresses are assigned for efficient use of the IP address pool, i.e. the device gets a new (changing) IP address each time a connection is set up.

Connecting is easier when the device is listed on a DNS server. The device logs in regularly leaving the device name, device IP address and the current Internet IP address. To connect to a device over the Internet you just insert the device name together with the URL of the DNS server which then returns the valid Internet IP address for automatic connection set up.

The default setting for the DNS server IP address is the IP address of the DNS server videotec.info. The VideoJet 10 contacts the server automatically when a refresh time is specified in the next

parameter. If e.g. the name of the VideoJet 10 is 'myVideoJet' just type myVideoJet.videotec.info as URL to set up a connection.



Note

Assign a unique name to the VideoJet 10 if you want to use this feature.

DNS refresh time:

Enter here the time interval for the VideoJet 10 to contact the DNS server. You can enter a value from 30 to 86400 sec (24 h). Leave this field empty when you don't want to use the DNS function.

Wireless LAN

Decoder connection	Installation Wizard	Expert Mode
Wireless LAN configuration		
WLAN IP address:	<input type="text" value="10.0.14.19"/>	
WLAN subnet address:	<input type="text" value="255.255.255.0"/>	
Network name:	<input type="text" value="Default_SSID"/>	
WLAN port type:	<input type="text" value="BSS (Infrastructure mode)"/>	
Channel settings:	<input type="text" value="Default Channel"/>	
Access point density:	<input type="text" value="Low"/>	
WLAN Encryption:	<input type="text" value="Encryption"/>	<input type="button" value="Set"/>
Wireless LAN link status		
Connection State:	No WLAN adapter found!	
Current transmission rate:		
Link quality:	<input type="text" value=""/>	0 %
Help on this page?		

Apart from the integrated Ethernet adapter of the VideoJet 10 a suitable Wireless LAN adapter card can be inserted at the Compact-Flash slot of the device. Thus the VideoJet 10 can be easily integrated into an existing Wireless LAN, without the need of additional wiring of CAT.5 network cables.



Warning!

When setting up a Wireless LAN take account of the technical information of all devices, e.g. Access Points or WLAN cards.

WLAN IP address:

For connection via Wireless LAN a dedicated Wireless LAN IP address must be assigned to the VideoJet 10. This IP address must refer to a subnet other than the Ethernet IP address.

Enter here the IP address for the Wireless LAN.

WLAN subnet address:

Enter here the subnet address referring to the WLAN IP address.

Network name:

In order of two devices being connected over WLAN they must belong to the same WLAN.

Enter here the name of the desired Wireless LAN.

WLAN port type:

Here you decide on the port type used for the Wireless LAN connection:

- 'BSS (Infrastructure mode)': Connection via Access Point
- 'IBSS (Peer-to-peer mode)': Direct connection to another WLAN capable device, e.g. laptop or VideoJet device

Channel settings:

Choose here the channel for the WLAN connection.



Warning!

Transmitter and receiver must use the same channel to enable transmission.

Access point density:

Enter here a value indicating the number of available Access Points. Choose 'High' if the number is large, 'Low' if only a few Access Points are available.

WLAN encryption:

WLAN connections are not protected against unauthorized access. It is possible to code the data with an encryption key for security.

☞ Click on the button 'Encryption' to open the respective window.

Channel Encryption:

You can choose out of four settings with different security levels:

- 'No Encryption' means the data is not protected with an encryption key. A connection is only set up when the encryption functionality on the remote device is disabled, too.
- 'Open System' means the encryption used is depending on the settings of the remote device. If the remote device operates with an encryption key, the local unit must have the same key for communication. When the remote device operates without an encryption key no WEP keys are required on this device.
- 'Shared Key' stands for permanent WLAN standard encryption. Encryption keys of 40 or 104 Bits of length are used in this mode. Remote and local device must use identical keys to enable transmission.
- 'Shared Key 128' stands for permanent encryption with 128 Bits for the Wireless LAN connection. This mode is only possible when a Prism II chipset is used on both devices connected. This mode does not correspond to a Wireless LAN standard mode.

WEP key index:

When encryption is activated on both ends of the WLAN connection the same WEP key index must be used to enable transmission.

WEP key 1-4:

Enter here the four keys if you want to protect the connection. The keys can be entered as standard text in ASCII format or as hexadecimal value. Standard text can be 5 or 13 Bytes of length for 'Shared Key' and 16 Bytes for 'Shared Key 128'. When entering hexadecimal digits the key can be 10 or 26 Bytes of length for

'Shared Key' and 16 Bytes for 'Shared Key 128' (sample for hexadecimal WEP key with the length 10: FFFBEEEE12A). All four keys must have the same length.



Warning!

Connection is only possible when both ends use the same encryption parameters.

Connection state:

Here the connection state of the WLAN adapter is displayed. The following messages are possible:

- 'No WLAN adapter found'
- 'Connecting! Try to establish connection'
- 'Connection successfully established' with a data rate of 11, 5.5, 1 or 2 MBit

Current transmission rate:

This text message box informs about the current transmission rate from the local Wireless LAN adapter to the remote device.



Warning!

Wireless LANs do not guarantee a specific data rate, as it depends on the intensity of the destination field. The de facto data rate is conditioned by the weakest link within the WLAN.

Link quality:

The value indicates the quality of the current Wireless LAN connection. A value of 100% stands for best link quality to the next Access Point or remote device. A value less than 15% indicates very poor quality at a critical limit.

Version information

Decoder connection Installation Wizard Expert Mode

Version information

Hardware version:

Software version:

[Help on this page?](#)

Hardware and software version numbers are only required for information and cannot be altered. Keep a record of these numbers in case technical assistance is required.

Hardware version:

The hardware version number of the VideoJet 10 is shown.

Software version:

The software version number of the VideoJet 10 is shown.

Software update

Decoder connection Installation Wizard Expert Mode

Software update

Software upload:

Upload progress:

Configuration download:

Configuration upload:

[Help on this page?](#)

Software upload:

The VideoJet 10 is designed in such a way that its functions and parameters can be updated with firmware. In such cases, transmit the updated firmware package via the selected network to the device. On termination of the connection, the firmware will be automatically installed.

This allows a device to be remotely serviced and updated without a technician having to modify the device installation on site.

The latest firmware can be obtained from your Service centre



Warning!

Before starting the firmware upload, ensure that you have selected the correct upload file! An upload of other files can result in the device being no longer addressable and having to be replaced.

On no account interrupt the installation of the firmware. An interruption will result in damage to the flash EPROM. This can result in the device being no longer addressable and having to be replaced.

- ☞ First, store the update files to the hard disk.
- ☞ Enter the complete directory path for the update file in the text field or click on the button **Durchsuchen...** to locate and select the file.
- ☞ Click on the button **Upload** to begin the transmission to the unit. The progress of the download can be monitored from the status messages and from the progress bar.

On completion of a successful upload, the unit will automatically restart.

If the LED **Power** flashes red and green alternately, the upload has been unsuccessful and must be restarted. In order to perform the upload, it is necessary to change over to a special page:

- ☞ Enter `/main.htm` in (e.g. `192.168.0.12/main.htm`) in the address field of the browser behind the IP address of the unit.
- ☞ Restart the upload process.

Configuration download:

You can store the configuration setting of the device on a PC.

- ☞ Click on the button **Download**. A dialog window is opened.
- ☞ Follow the instructions in the dialog window to save the settings.

Configuration upload:

You can upload stored configuration settings from a PC.

- ☞ Enter the complete directory path of the file to be uploaded or click on the button **Durchsuchen...** to select the desired file.
- ☞ Ensure that the download file originates from the same type of device that you want to reconfigure.

-
- ☞ Click on the button **Upload** to start the transmission of the file to the device.

After a few seconds the message **Configuration upload finished. State: Configuration upload ok. (system must be rebooted)** will be displayed and the countdown for the reconnection is shown.

- ☞ Restart the device.

At the next call-up of the configuration page **Software update** the message **Configuration upload ok** confirms the successful completion of the upload. If the message **Configuration upload failed** is displayed the file was not correctly uploaded (e.g. because it did not originate from the same type of device). Repeat the upload procedure, possibly with a different file.

Function test

The VideoJet 10 provides a number of configuration possibilities. Therefore you should check it operates correctly after installing and configuring.

It is only possible to ensure that the VideoJet 10 will operate correctly in an alarm situation this way.

Check for the following features:

- the VideoJet 10 can be remotely dialled up
- the VideoJet 10 transmits the required data
- the VideoJet 10 reacts to alarm events in accordance with the configuration
- where applicable, that the control of peripheral equipment is possible

Operation with MS Internet Explorer

The reception of live video images sent from the VideoJet 10 is possible on a computer with Microsoft Internet Explorer installed (version 5.5 or higher).



Note

In order to decode live video images, the required special ActiveX control must be installed on the computer. The latest version of the ActiveX control can be obtained from customer service

Instructions for the operation of the web browser will be found under the online help of the web browser.

System requirements

- Microsoft Internet Explorer (version 5.5 or higher)
- Monitor resolution 1024 x 768 pixels
- Access to network (Intranet or Internet)



Note

Make sure the graphic card is set to a color depth of 16 or 32 Bit and the Microsoft Virtual Machine is installed on your computer.

MPEG decoder installation

If no video images are displayed when MPEG-4 is selected, installation of a current MPEG decoder is probably necessary. Suitable software for this can be found on the supplied program CD

- Insert the CD into the CD-ROM drive of the computer. The CD runs automatically. If the CD does not start automatically, open the root directory of the CD in Windows Explorer and double click on **MPEGAx.exe**.
- Follow the onscreen instructions.

Establishing the connection

To use the VideoJet 10 on a network, it must be provided with an IP address.

The following address is factory installed:

Transmitter: **192.168.0.1**

Receiver: **192.168.0.2**

- Start up the web browser.
- For the URL, enter the IP address of the VideoJet 10. If the IP address refers to a transmitter the Livepage with the video image will be displayed.

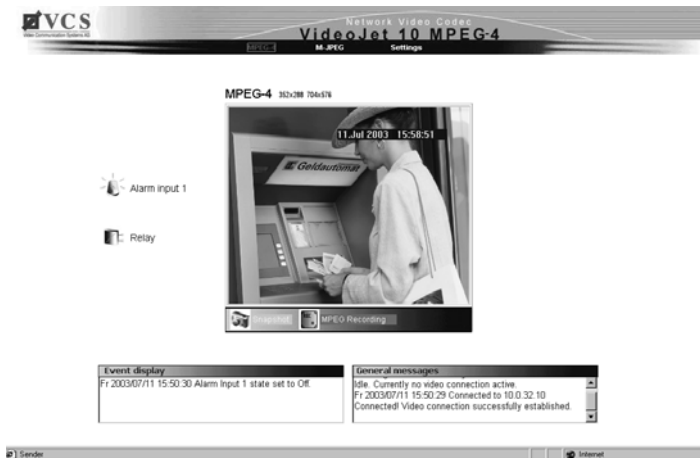

If the connection is not established, the selected transmitter is already occupied with a different destination. Depending upon network configuration and individual units, a maximum of five receivers can receive images simultaneously from one transmitter.

Detailed information on receivers you find starting on page 113.

Image quality

With established connections, the video image is displayed in the middle of the browser window. Depending upon configuration, other information may also appear in the display (see page 42).

The VideoJet 10 provides either a live image (MPEG-4 format) or single video frames in JPEG format.

- ☞ Click on the link **MPEG-4** in the navigation bar at the top of the screen in order to display or decode the video sequences in the corresponding image format
- or
- ☞ click on the link **M-JPEG** in the navigation bar at the top of the screen in order to display or decode the single video frames in the corresponding image format.
- ☞ Above the video image, click on one of the links **352x288** or **704x576**, to display the image in the selected resolution.

Alarm

In the event of an alarm, the alarm symbol is displayed in red along with the video image. The display of alarms and other details depends on the configuration of the unit (see page 75).

Output

Depending upon configuration, equipment can be switched by the relay of the VideoJet 10 (e.g. a floodlight or door opener).

- ☞ To activate the relay output, click on the relay symbol beside the video image. The symbol will be displayed in red when the relay is activated.

Control functions

Possibilities for the control of peripheral equipment (e.g. pan and tilt heads) are dependent upon the installed equipment type and on the configuration of the VideoJet 10.

If a controlled unit is connected to a VideoJet 10 and configured, the active elements for the control of the peripheral unit (e.g. a dome camera) will be displayed alongside the video image.



Panorama view

Using a Sony camera EVI-D100 or EVI-D30/31 you can display a panorama of the site. To do so the parameter Panorama view on live page resp. **Show panorama view** on the Livepage configuration page has to be activated (see page 76).



Each time the Livepage is called up automatically a panorama of the site consisting of 5 snapshots is generated and displayed above the live picture.

The snapshots can be updated anytime by clicking into the pictures with the right mouse button and selecting **Start scan**.

The update can be canceled by selecting **Stop scan** out of the same menu.

Storing snapshots

It is possible to store individual images from the current video sequence in the Livepage in JPEG format on the computer hard drive.

- ☞ Click on the symbol **Snapshot**. The image will be stored. The storage location is specified during configuration of the unit (see page 75).



Image resolution Individual images can be displayed at different resolutions when the snapshot is taken entering a command into the Internet address field. To do so just append the corresponding parameter to the command **snap.jpg**:

snap.jpg?JpegSize=XS	128 × 96 pixels
snap.jpg?JpegSize=S	176 × 144 pixels
snap.jpg?JpegSize=M	352 × 288 pixels
snap.jpg?JpegSize=XL	704 × 576 pixels

Without this additional parameter, the image size will be 352 × 288 pixels.

- ☞ In the field for the Internet address (URL), enter the IP address of the VideoJet 10, followed by the command **/snap.jpg** (for example: <http://192.168.0.12/snap.jpg>).
- ☞ Press the return key on the computer. A single frame image will be displayed in a new window.
- ☞ Using the mouse onscreen, press the right mouse button and select the command **Save image as...**
- ☞ Store the single image in the required format under a new name.

Storing video sequences

You can store video sequences either on the hard drive of your computer or locally on the device. For the local recording via the CompactFlash interface you can use standard CompactFlash cards or MicroDrives with a capacity of up to 1 GB. The video sequences are stored in MPEG format.

- ☞ Click on the symbol **MPEG Recording** to start recording a video sequence. The storage location depends on the configuration of the VideoJet 10 (see page 75).



The recording starts immediately. While storing the red dot in the symbol **MPEG Recording** is blinking.

- ☞ Click on the symbol **MPEG Recording** once more to stop the recording.



Note

Use the MPEG Player to display the recorded video sequences. You can find the latest version of the MPEG Player on the supplied software CD. It is also available from your service centre

For further information on installing the MPEG decoder see page 103.

Image resolution Video sequences will be recorded with the resolution specified for the encoder that is chosen as source for the Livepage video (see pages 43 et sqq. and 75).

Harddisk activity

When a program is running in the background to make an automatic recording on the storage medium of the VideoJet 10, the hard disk symbol changes to act as an indicator.

The hard disk symbol is animated to show that recording is in progress. When recording is not taking place then the symbol remains still:



Playback of recorded sequences

To play back recorded video sequences click on the Media-Replay link available on the Livepage or Expert Mode page at the top of the screen.

The screenshot displays the VideoJet 10 MPEG-4 interface. The main window shows a video playback of a woman at an ATM. The video title is "cam 40.18" and the timestamp is "10-Jul 2003 16:12:15". The interface includes a menu bar with "MPEG-4", "M-JPEG", "Settings", and "Media-Replay". A "Partition name" dropdown is set to "Partition 1". A table on the right lists recorded tracks with columns for Track, Starttime, Stoptime, Duration, Alternate, and Type.

Track	Starttime	Stoptime	Duration	Alternate	Type
0	07/10/2003 18:02:43	07/10/2003 18:02:54	00:00:11		Time
1	07/10/2003 18:03:10	07/10/2003 18:04:03	00:00:53		Time
2	07/10/2003 18:18:54	07/10/2003 18:17:22	00:00:29		Time
3	07/10/2003 18:17:59	07/10/2003 18:22:05	00:04:06		Time
4	07/10/2003 18:24:13	07/10/2003 18:28:36	00:04:23		Time
5	07/14/2003 15:28:36	07/14/2003 15:36:55	00:08:19		Time

Choosing the sequence

First you have to select under **Partition name** the partition the recorded sequence is on.

All sequences stored on the selected partition will be listed. For each sequence you will see a recorded order number, the start and stop times of the recording, the length of the recording, and the number and type of alarms captured during the sequence.

Click on any of the listed sequences to start the playback of that recording in the viewing window.

Playback control

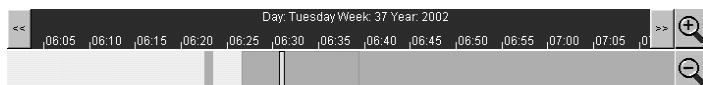







Below the video window you can see a time slice for easy orientation. After loading the HDD-Replay page the blue bar is showing the current day, week and year and a time scale with two-hours interval.

When a special sequence was selected the regarding time section is shown in the lower bar, the selected sequence is symbolized by a blue mark with a green border. The yellow slider gives the position of the currently replayed picture within the sequence.

The time slice provides various possibilities to navigate within and inbetween the sequences:

- ☞ Change the time section displayed by clicking on the << or >> button or by moving the blue bar to the left or to the right with the mouse button held down.
- ☞ Change the graduation by clicking on the 'Zoom-in' or 'Zoom-out' symbol. Select between intervals of three days, one day, two hours, five minutes or one minute.
- ☞ Select another sequence for replay by clicking in the corresponding blue mark. The green border will signify the active sequence.
- ☞ You can start the replay also by positioning the mouse on the yellow strip, clicking on the mouse button and holding it down while moving the strip on the video bar to the time position you desire. Detailed information on date and time is provided by the indicator below the video bar.

You can control playback of the sequence using the buttons below the video window. The buttons have the following functions:

-  Jump to the beginning of the video recording, jump to the previous alarm
-  Fast rewind, rewind in intervals of 0.5 sec (only in Pause mode)
-  Stop
-  Play
-  Pause
-  Fast forward, forward frame by frame (only in Pause mode)
-  Jump to the end of the video recording, jump to the next alarm

With the slider you can control the velocity of replay. 100% gives regular velocity, lower values decelerate, higher values accelerate.



Red strips on the video bar indicate alarm activations. You can quickly jump to the alarm activations using the control buttons or the yellow slider.

Back-up

You can save video recordings that are on the storage medium of the VideoJet 10 directly to the hard drive of your computer as back-up.

First choose which sequence you would like to save to your computers hard drive as described above. The following buttons are for recording information directly to your computers hard drive:



Back-up of a sequence directly to the hard drive of your computer



Back-up of a snapshot to the hard drive of your computer

- ☞ Start the playback of the sequence you want to back-up as a whole or in parts.
- ☞ Click on the symbol for back-up of a sequence. Storing starts at once and is indicated by slowly blinking of the symbol on the button.
- ☞ Click on the symbol for back-up of a sequence once more to stop recording.

You can repeat the procedure several times within a sequence if you want to back-up several sections out of a longer sequence.

- ☞ Click on the button for snapshots to store individual video frames out of the sequence replayed to the hard drive of your computer.

The snapshots taken will be displayed immediately in the area to the left.



The location of the recordings on the hard drive can be selected in the settings of the VideoJet 10 (see page 75).

Hardware connections between VideoJet units

A VideoJet 10 with connected camera as a transmitter and a VideoJet 10 with connected monitor as a receiver can be linked together simply over an Ethernet network or a Wireless LAN. It is thus possible to link large distances with little installation or cabling effort.

Installation

With the appropriate configuration the VideoJet 10 units can automatically establish a connection with each other. This assumes that, as a minimum, they are linked into a closed network. To install the units proceed as follows:

-  Connect the units into the closed network using Ethernet cables or a Wireless LAN card.
-  Connect power to the units.



Note

Make sure the units are configured for the characteristics of the network environment and that the transmitting unit, under the parameter **Live video receiver IP address**, is set for the IP address of the receiver (see page 58).

Connection setup

It is possible to configure the connection using a Terminal software or by appropriate configuration via the alarm input. After a brief pause, the live image from the camera will be displayed on the connected monitor.



Note

It is only possible to establish the connection using the alarm input if the parameter **Connect on alarm** is set to **On** on the configuration page **Alarm connections** (see page 57).

- ☞ Activate the alarm input,
or
- ☞ start the terminal program (see page 26); enter the command `I` to switch to the **IP** menu.
- ☞ In the **IP** menu enter the command `r` to change the remote IP address and enter the IP address of the device that is to be connected.
- ☞ In the **IP** menu enter the command `a` to activate the automatic connection set up.

As an alternative you can set up a connection using the Microsoft Internet Explorer:

- ☞ Start up the web browser.
- ☞ For the URL, enter the IP address of the VideoJet 10 receiver. The Decoder connection page will be displayed.

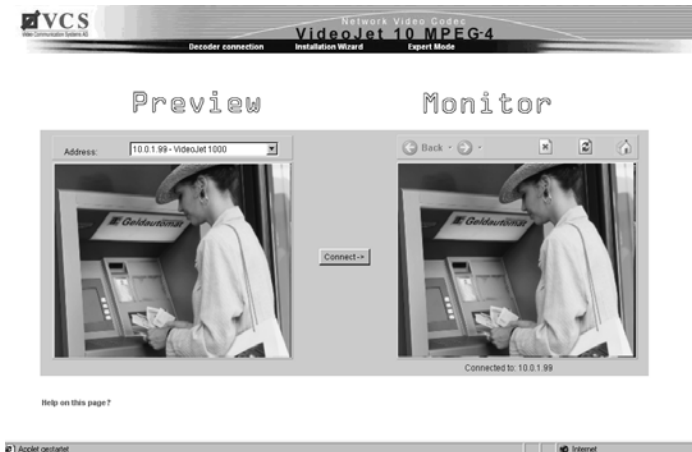

After the start the VideoJet 10 receiver automatically scans the network for available transmitters.

- ☞ Select a transmitter out of the **Address** list. A JPEG snapshot of the chosen video source will be displayed in the **Preview** window.

- ☞ Click on **Connect ->** to start the display on the connected monitor. A JPEG snapshot of the connected video source will be displayed in the **Monitor** window.

The buttons on top of the **Monitor** window allow easy navigating comparable to the Internet Explorer:

- ☞ Click on the arrow buttons to switch between connections that had already been established during the session.
- ☞ Click on the button with the red cross to cut off existing connections.
- ☞ Click on the button with the green arrows to refresh the JPEG snapshot in the **Monitor** window.
- ☞ Click on the button with the house symbol to reestablish the connection that was active when the web page was loaded.

Terminate connection

Termination of the connection is possible with the aid of the terminal program or with the web browser.

- ☞ Start the terminal program (see page 26); enter the command `I` to switch to the **IP** menu.
- ☞ In the **IP** menu enter the command `a` to deactivate the automatic connection set up,
or
- ☞ start up the web browser.
- ☞ For the URL, enter the IP address of the VideoJet 10 receiver. The startpage will be displayed.
- ☞ Click on the button with the red cross on the top of the **Monitor** window to stop the display on the connected monitor.

Operation with Software-Decoder

The video server VideoJet 10 in association with the program VIDOS comprises a powerful systems solution.

VIDOS is a program for the operation, control and administration of CCTV installations (e.g. surveillance systems) at remote locations. It runs under the Windows operating system. It primarily provides decoding of video, audio and control data received from a remote transmitter.

During operation of a VideoJet 10 with VIDOS, a multiplicity of operating and configuration options are offered. For details, see the documentation provided with the software.

Network check

The connection between two IP addresses can be checked by means of the `ping` command. In this way it is possible to check whether a unit is active on the network.

- ☞ Open the DOS input window.
- ☞ Enter the command `ping` followed by the address of the unit.

When the unit is found, the response: `Reply from...`, followed by the number of bytes transmitted and the time taken for the transmission in ms is displayed. If this message is not displayed, the unit is not accessible over the network. This can be due to the following reasons:

- The network connection to the unit is not OK. In this case, check out the cable connections.
- The unit is not correctly integrated into the network. Check the IP address, subnet mask and, if necessary, the gateway IP.

Repair



Warning!

Never open the housing of the VideoJet 10. The unit has no user serviceable parts, which can be repaired or exchanged.

Ensure that only qualified, specialist personnel (electrical technicians) are permitted to carry out maintenance or repair work or contact the Service centre.

Passing on, Disposal

The VideoJet 10 should only be passed on together with this manual.

The device and the plug-in power supply contain environmentally harmful materials, which must be disposed of in accordance with legal requirements.

Faulty units and parts, which are no longer required, should be disposed of professionally or, if necessary, contact the local authorities for the disposal of harmful objects and substances.

Faults – possible causes and remedy

If a fault can not be cleared, please contact the Customer Service

The version numbers of the internal processors can be shown on a special page. Note this information before contacting the Customer Service.

- ☞ In the address field of the browser behind the IP address of the unit, enter `/version.htm` (e.g. `192.168.0.12/version.htm`).
- ☞ Make a note of all details or print out the page.

The following table is intended to help identify reasons for malfunctions and, where possible, to suggest remedies.

Problem	Possible causes	Suggested remedy
No connection between unit and terminal program.	Faulty cable connections.	Check all leads, plugs, contacts and connections.
	The computer's serial interface is not connected.	Check other serial interfaces.
	Interface parameters do not match.	If necessary, select a different COM port, make sure that the computer's interface parameters match with those of the unit. Possibly select the following standard parameters: 19,200 Baud, 8 data bits, no parity, 1 stop bit. Subsequently turn off power to the unit and turn on again after a couple of seconds.
No picture transmission to remote station.	Defective camera.	Connect local monitor and check camera function.
	Faulty cable connection.	Check all leads, plugs, contacts and connections.

Problem	Possible causes	Suggested remedy
No connection established, no picture transmission.	Configuration of the unit.	Check all configuration parameters.
	Faulty installation.	Check all leads, plugs, contacts and connections.
	Wrong IP address.	Check IP address (terminal program).
	Faulty data transmission within LAN.	Check data transmission with the command <code>ping</code> .
	The maximum number of receivers is connected.	Wait until a new connection is possible and dial again.
No audio transmission to outstation.	Defective hardware.	Check perfect functioning of all audio devices connected.
	Faulty cable connection.	Check all leads, plugs, contacts and connections.
	Faulty configuration.	Check configuration of audio settings (interface, audio level and coding mode).
	Audio voice connection is occupied by another receiver.	Wait until the connection is free and dial again.
The unit does not report an alarm.	Alarm input not selected.	Select alarm input on configuration page Alarm sources .
	No alarm action selected.	Select alarm action on configuration page Alarm connections . If necessary change IP address and e-mail address.
Control of PTZ cameras or other devices not possible.	Cable connection between the RS232 interfaces and the connected device is incorrect.	Check all cable connections and ensure all plugs are properly plugged in.
	The interface parameters conflict with the other devices connected.	Make sure the settings of the devices involved agree with each other.
The unit is not ready for operation after firmware upload.	Voltage failure while the update file is being programmed.	Replace the device and have it checked.

LEDs

The VideoJet 10 video server is equipped with several LEDs which indicate the operating status and can give indications of possible faults:

Power	Not lit:	Device is switched off.
	Flashing green:	Device is switched on.
	Lit red (temporary):	Device is starting.
	Lit red (permanent):	Device is out of order.
	Flashing green/red:	Upload failed.
I	Lit red:	Alarm input activated.
	Not lit:	Alarm input inactive.
O	Lit green:	Relay switched.
	Not lit:	Relay inactive (rest state).
L	Lit green:	Physical connection to the network established.
	Not lit:	No network connection.
T	Flashing yellow:	Data transmission via the network.
	Not lit:	No data transmission.

Glossary

A few brief explanations of the most important terms and abbreviations from the field of communications technology can be found below.

10/100 Base-T	IEEE 802.3 specification for 10 or 100 Mbit/s Ethernet
ARP	Address Resolution Protocol
Baud rate	Data transmission rate
bit/s	Bit per second, the actual data rate
CIF	Common Intermediate Format, video format with 352 × 288 pixels
DHCP	Dynamic Host Configuration Protocol: Protocol for dynamic allocation of IP addresses
DNS	Domain Name Service
FTP	File Transfer Protocol
Full duplex	Simultaneous data transmission in both directions
G.711, G.728	Standard audio coding algorithms defined by ITU-T
H.224	Standardized protocol for data communication and remote control
H.261	Standard motion video coding algorithm defined by ITU-T
HTTP	Hypertext Transfer Protocol
HTML	Hypertext Markup Language
Hub	Multiplexer to connect a number of Ethernet units to a 10 BASE-T segment
ICMP	Internet Control Message Protocol
ID	Identification: machine readable number or name
IEEE	Institute of Electrical and Electronics Engineers
IGMP	Internet Group Membership(management) Protocol

Internet protocol	The main protocol used in the Internet. Forms in conjunction with the Transfer Control Protocol (TCP) the TCP/IP
IP	See Internet Protocol
IP address	A 4-byte number uniquely defining each unit on the Internet. Usually written in dotted-decimal notation with periods separating the bytes
ISDN	Integrated Services Digital Network
ISP	Internet Service Provider
JPEG	Procedure to encode still images (Joint Photographic Experts Group)
kBit/s	Kilobit per second, the actual data rate
LAN	See Local area network
Local area network	A communications network serving users within a limited geographical area, such as a building or a campus, controlled by a network operating system and using a transport protocol.
MAC	Media Access Control
MPEG-1	Video compression standard, initially hardware-dependent, now also possible with software.
MPEG-2	Enhanced video compression standard, high-level compression facilitates images with studio quality, meanwhile established as broadcasting standard.
MPEG-4	Further development of MPEG-2, used for transmission of audiovisual data with very low transfer rates (e.g. via Internet).
NAT	See Network Address Translator
Netmask	A mask that explains which part of an IP address is the network address and which part comprises the host address. It is usually expressed in dotted-decimal notation, e.g. 255.255.255.192
Network address translator	A proposal for IP address reuse, where the local IP address is mapped to a globally unique address.
Parameter	Values used for the configuration of the network system

Picture	A video picture that has been digitized at a given resolution
PPP	See Point-to-point protocol
Point-to-point protocol	A protocol allowing a computer using TCP/IP to connect directly to the Internet
QCIF	Quarter CIF, video format with 176 × 144 pixels
Server push	A continuous stream send from the transmitter to the web browser
SNMP	Simple Network Management Protocol
Subnet mask	See Netmask
TCP	Transfer Control Protocol
UDP	User Datagram Protocol
URL	Uniform Resource Locator
UTP	Unshielded Twisted Pair
V.24, RS-232	A list of definitions for the transmission between DTE and DCE
WAN	See Wide area network
Wide area network	A long distance link used to extend or connect remotely located local area networks
Wireless LAN, WLAN	Radio linked local area network

Specifications

Operating voltage	12 ... 24 V DC, power supply included
Power consumption	approx. 10 W
Network interface	Ethernet 10/100 Base-T auto sensing, RJ45; RF-interface 802.11b via CF card interface
Data rate	9.6 kBit/s ... 4 MBit/s (MPEG-4)
Audio data rate	80 kBit/s
Audio sampling rate	8 kHz
Video standards	PAL, NTSC
Video resolution	704 × 576 pixels 704 × 288 pixels 352 × 288 pixels 176 × 144 pixels
Overall delay	100 ms
Video coding protocols	ISO/IEC 14496 (MPEG-4)
Audio coding protocols	G.711; 300 Hz - 3.4 kHz
Network protocols	RTP, RTCP, UDP, TCP, IP, HTTP, IGMP, ICMP, ARP, SNMP
Video input (sender only)	1 × BNC jack 0.7 - 1.2 V _{p-p} , 75 Ohm switchable, PAL/NTSC
Video output (receiver only)	1 × BNC jack 1.0 V _{p-p} , 75 Ohm, PAL/NTSC
Audio input	1 × mono line, stereo jack 3.5 mm, 1 V _{p-p} , 50 kOhm
Audio output	1 × mono line, stereo jack 3.5 mm, 1 V _{p-p} , 60 mW, min. 8 Ohm
Data interfaces	1 × RS232/RS422/RS485, bidirectional, 9-pin sub-D, 1 × RS232, 9-pin sub-D

Alarm input	1 × clamp (non-isolated closure contact type), max. 24 V, max. activation resistance 10 Ohm
Analog sensor input	0 - 5 VDC (e.g. temperature sensor)
Relay output	1 × clamp, 30 V _{p-p} , 1 A
Storage media	CompactFlash card type I and II, Microdrive
LED displays	5 × LED (Power, Alarm In, Alarm Out, Link, Traffic)
Operating conditions	temperature: 0 ... +50 °C relative humidity: 20 ... 80 %, non-condensing, altitude 0 ... 3,000 m
Storage conditions	temperature: -20 ... +60 °C relative humidity: 0 ... 95%, non-condensing, max. altitude 10,000 m
Regulations	CE: IEC 60950; UL 1950; J 60950; AS/NZS 3548; EN 55103-1, -2; EN 55130-4; EN 55022; EN 55024; EN 61000-3-2, EN 61000-3-3; FCC 47 CFR Ch. 1 Part 15
Dimensions (w × h × d)	143 × 33 × 135 mm 5.63 × 1.3 × 5.31 inches
Weight	approx. 400 g (without power supply)

A

- Activator 22
- ActiveX 31, 103
- Alarm input 22
- Audio connection 23
- Audio source 23
- Authorisation 40, 84
- Authorisation levels 40, 84

B

- Back-up 112
- Browser window 105
- Buttons 111

C

- Calendar 41, 85
- Camera name 42
- Closing contact 22
- Connection 104
- Control 64, 91
- Conventions 7

D

- Data interface 23
- Data terminal 26
- Date format 41, 85
- Display recorded video sequences 108

DNS server 67, 94
Dome camera 23
Dual encoding 43
Dynamic IP address 67, 94

E

Echo 27
Electromagnetic Compatibility 8
EPROM 78, 100

F

False alarm 59
Firewall 67, 94
Front panel 19
Function test 101
Functional overview 14

G

Gateway 67, 94

I

Identification 9
IGMP 73
Image resolution 107, 108
Installation 12
Installation requirements 21
IP address 27, 66, 93

L

Language 40, 84
Live video images 31, 103
Location for installation 21

Loudspeaker 23
Low-Voltage Guideline 8

M

Main functions 17
Maintenance 12
Monitor name 86
Motion detector 58
MPEG Playe 108
Multicast 72, 73
Multicast connection 67, 72
Multicast Function 15
Multicast port 73
Multi-unicast 72, 73

N

Network 22, 66, 93
Network connection 25
NTP server 41, 86

O

Operation 11
Output standard 86

P

Panorama 76
Parameter 28
Partition 47
Password protection 40, 84
Picture quality 73
Power switch 25
Protocol 65, 92

R

Rear panel 18
Receiver 14
Regulations 7
Relay output 23, 62, 89
Relay switch 63, 90
Remote control 15
Repair 12
Requirements 13
Router 74

S

Signal source 23
snap.jpg 107
SNMP 57, 87
Specifications 125
Subnet mask 66, 93
Symbols 7
Synchronous 41, 85

T

TCP 67, 94
Test 101
Time of day 41, 85
TIME server 41, 86
Time signal 41, 86
Time zone 41, 86
Transmission parameter 26
Transmission rate 64, 65, 91, 92
TTL 74
Typographic conventions 8

U

UDP 67, 94

Unicast 72
Upload file 78, 100
URL 32, 104, 114, 115

V

Version 74, 99
Video sensor 58
videotec.info 67, 94

W

Wireless LAN 68, 95
WLAN encryption 70, 97



SLD Security & Communications
The Old Forge, Ockham Lane, Ockham, Surrey GU23 6PH England
Phone: +44 (0) 1483 225633 Fax: +44 (0) 1483 225634
Email: sales@sld.co.uk Web: <http://www.sld.co.uk/>
