

Video Security



VTL-W/N2

Weatherproof Housing (300mm) with
Heater/Thermostat, 230VAC

Art-No. 79484



Wall bracket is not included with the housing

Features

Camera Weatherprotection
Fold-down Housing Body
Insulated Camera Mounting
Housing Body Length: 300 mm

3 Cable Entries
Screen Heater Included
Protection Rating: IP 66

Specifications

Housing length (L)	300mm
Length for power supply	50mm
Cable entries	2x M16x1.5mm; 1x M20x1.5mm
Window heater	220-240V / 20watts with thermostat
Sunshield	Yes
Protection rating	IP66
Housing	Aluminium
Colour	Silvergry anodized / black end caps
Dimensions (HxWxD)	See drawing
Weight	2.5kg

Accessories

79790 / WD-7/MK	Wall Mount with Swivel Head for VTL Series Outdoor Housings, black
79415 / NE-115	Power Supply Unit 230VAC/12VDC (400mA) for all VTL Housings, Regulated
79487 / VTL/H24-1	Window Heater 24VAC for VTL Housing
79593 / PM-6D	Pole Mount Adapter for 2 Wall Mounts, (50-140mm Pole), RAL9002

(Accessories continued)

79592 / PM-6S

Pole Mount Adapter for 1 Wall Mount, (50-140mm Pole), RAL9002

79614 / NE-127/12V

Power Supply Unit 230V/12VDC (1.0A) for Standard VTL-W/D N2 Housings

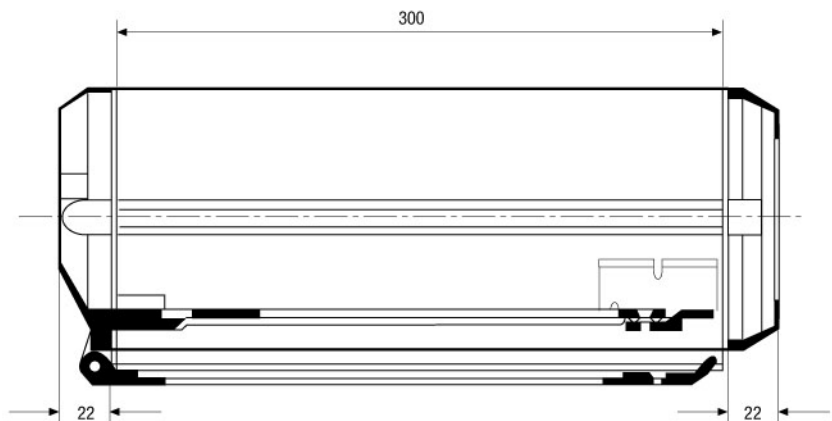
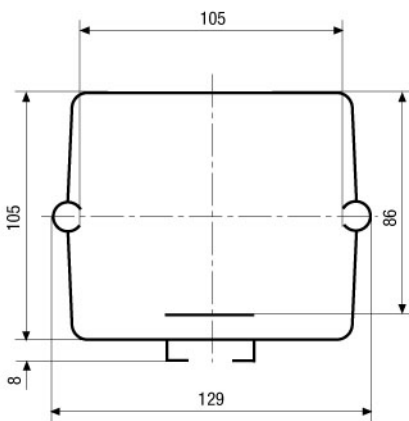
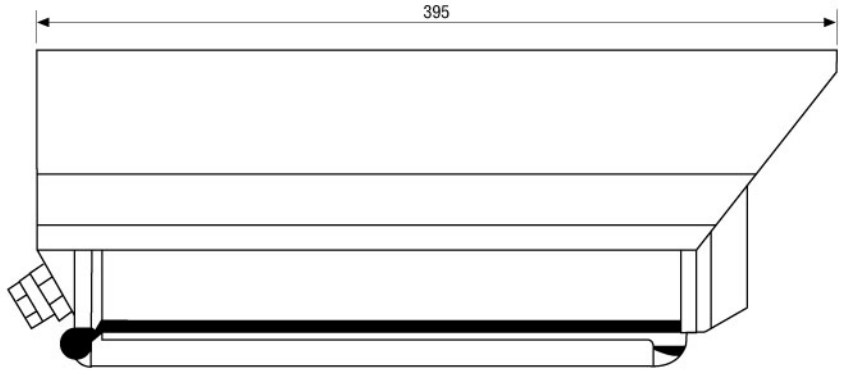
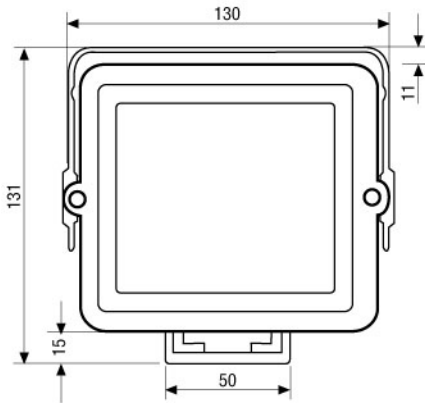

Maße/Dimensions: mm

SLD Security & Communications
 The Old Forge, Ockham Lane, Ockham, Surrey GU23 6PH England
 Phone +44.1483225633 · Fax +44.1483225633
 sales@sld.co.uk · www.sld.co.uk

