

VTL-DPW

Home | Security | Housings | for Boxed Cameras

VTL-DPW

Dustproof Housing (300mm) with Wallbracket,

RAL9002

Art-Nr. 79489



SLD Security &
Communications

Main Features

Dustproof Housing
With Integrated Wall Bracket
Housing Body Length: 300 mm

Insulated Camera Mounting
Cable Entries Through the Wall Bracket
Protection Rating: IP 66

Specifications

Series	eneo VTL
Maximum installation length	300
Cable entries	Through wall bracket
Clear Shield	no
Window heater	optional
Blower	optional
Wiper	no
Sunshield	no
Hidden cable management	yes
Integrated wall mount	yes
Protection rating	IP66
Housing	Indoor
Housing material	Aluminium
Colour (housing)	RAL9002
Dimensions (HxWxD)	See drawing
Weight	3.8kg

VTL-DPW

Optional accessories

79662

NE-130/12V

Power Supply Unit 230V/12VDC-1.25A for Housings VTL-WWA

VTL-DPW

Home | Security | Housings | for Boxed Cameras

Technical drawing

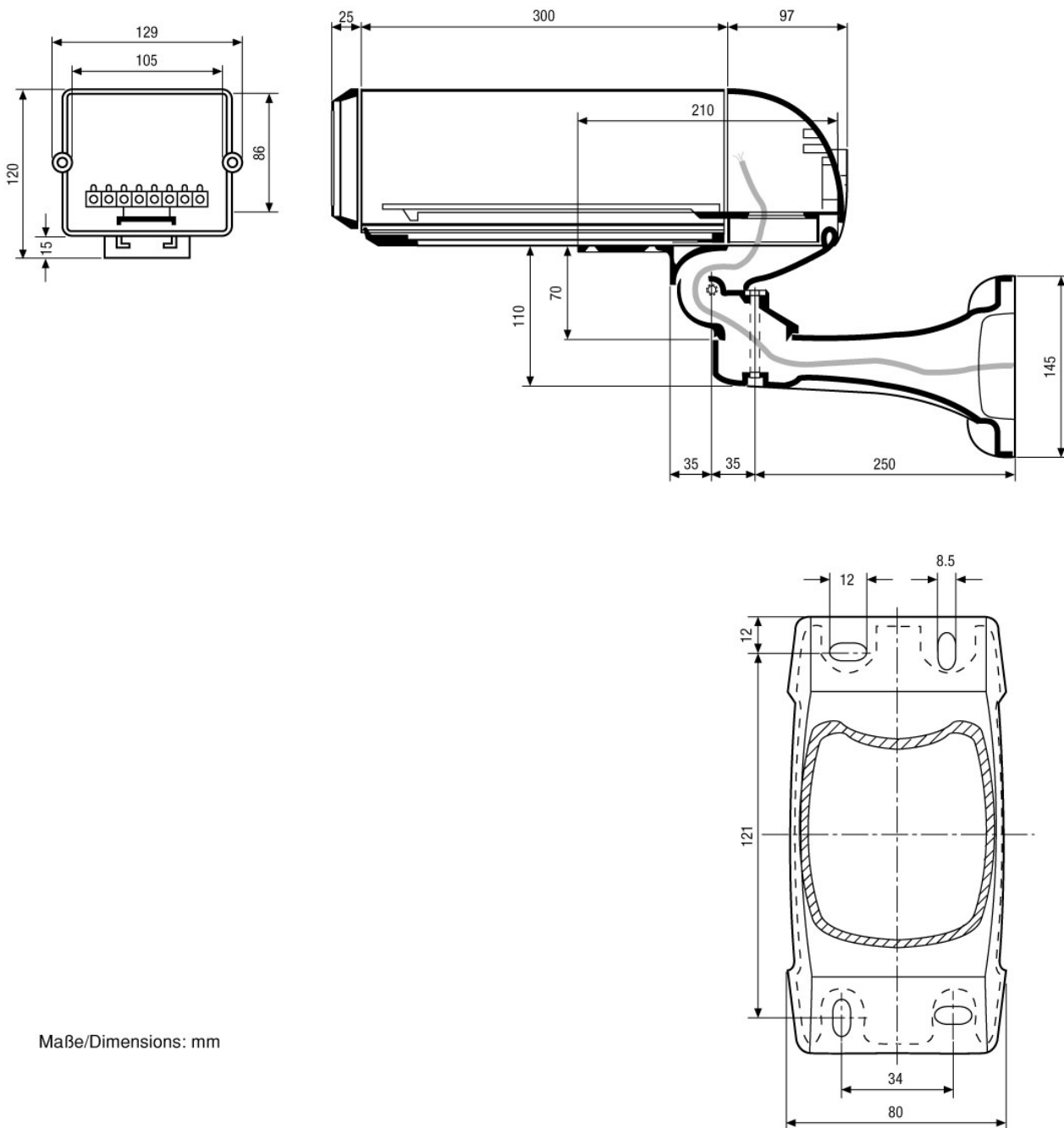

Maße/Dimensions: mm

SLD Security & Communications
The Old Forge, Ockham Lane, Ockham, Surrey GU236PH England
Phone +44.1483225633 · Fax +44.1483225634
sales@sld.co.uk · www.sld.co.uk

