

Video Security



VHM/ECLKB

Weatherproof Housing (330mm) with Heater, Thermostat/CBD, RAL7032, 24VAC

Art-No. 79428



Features

Camera Weatherprotection

Housing Body Length: 330mm

Fold-down Housing Body

4 Levels of Camera Height Adjustment

Insulated Camera Mounting

Integrated Connection Board

3 Cable Entries

Screen Heater 12-30V Included

Viewing Screen with "Clear-Shield" Technology

Incorporated Carrier Handle

Housing Surface: RAL7032

Specifications

Maximum installation length	330 mm
Length for power supply	NE-112 (1 output): 85 mm; NE-112/2 (2 outputs): 110 mm
Cable entries	3x M16x1,5
Window screen	Coated with "Clear Shield" Technology. With this technology the glass corrosion, caused by environmental pollution, is avoided and screen cleaning cycles will be extended. The coating is UV light resistant, colour neutral and it causes no F-stop loss.
Window heater	12-30VAC/DC, 9watts
Thermostat	On: +16°C, Off: +20°C
Sunshield	Yes
Housing	Aluminium w. plastic end caps
Colour	RAL 7032
Protection rating	IP 66
Parts supplied	Screw set, thermostat, screw terminal
Dimensions (HxWxD)	See drawing
Weight	2.8 kg

73064 / WD-16/MK

Wall Mount with Swivel Head for VHB/VHM Weatherproof Housings, RAL7032

71301 / VHM/H220

VHM Window Heater 110-265VAC (PTC Element)

79623 / VHM/PC-1

Plug-in shield for VHM/EC&ST Housing Series, 330mm

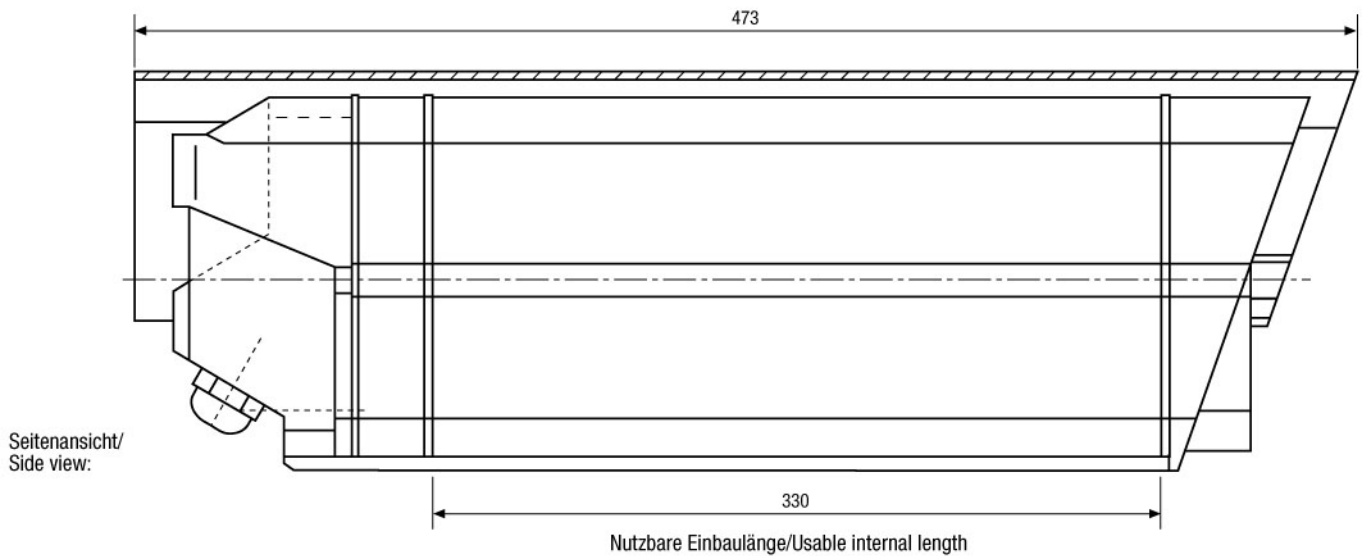
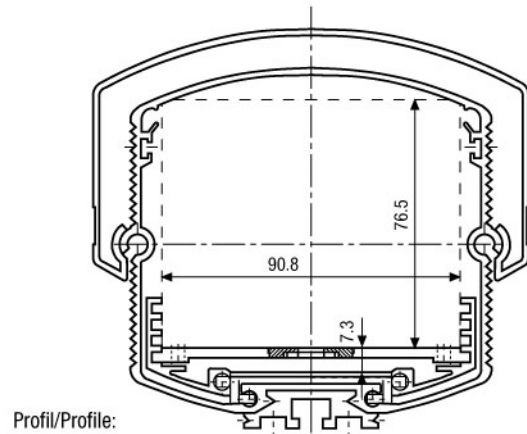
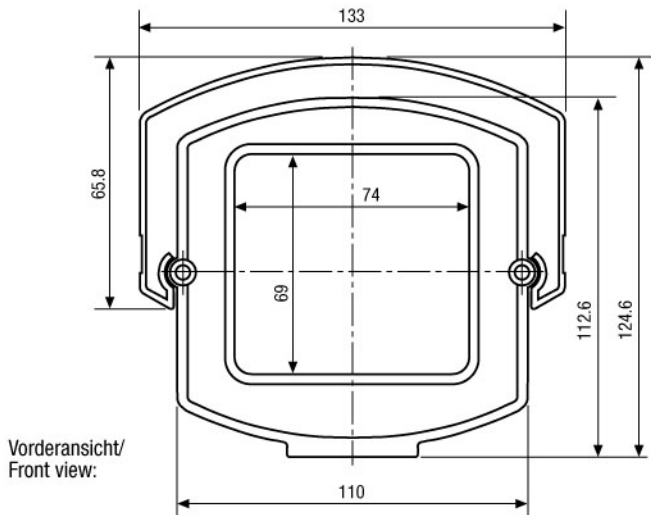

Maße/Dimensions: mm

SLD Security & Communications
 The Old Forge, Ockham Lane, Ockham, Surrey GU23 6PH England
 Phone +44.1483225633 · Fax +44.1483225633
 sales@sld.co.uk · www.sld.co.uk

