

VHM/ECLKB-210-W

Home | Security | Housings | for Boxed Cameras

VHM/ECLKB-210-W
Weatherproof Housing (210mm), Heater, CBD,
RAL9016/7035, 24VAC

Art-Nr. 79677



Main Features

Camera weather protection	3 cable entries M16x1.5mm
Housing body length: 210mm	PTC window heater 12-30V included
Fold-down housing body	Window glass with "Clear-Shield" technology
4 levels of camera height adjustment	Incorporated carrier handle
Insulated camera mounting	Protection rating: IP66
Integrated connection board	Housing colour: RAL9016/RAL7035

Specifications

Series	eneo VHM
Maximum installation length	210
Cable entries	3x M16x1.5mm
Window screen	Coated with "Clear Shield" Technology. With this technology the glass corrosion, caused by environmental pollution, is avoided and screen cleaning cycles will be extended. The coating is UV light resistant, colour neutral and it causes no F-stop loss.
Clear Shield	yes
Window heater	yes, 12~30V/9watts (PTC)
Thermostat	On: +16°C, Off: +20°C
Blower	no
Wiper	no
Supply voltage	12~30VAC/DC
Sunshield	yes

VHM/ECLKB-210-W

(Continuation Specifications)

Hidden cable management	no
Integrated wall mount	no
Protection rating	IP66
Housing	outdoor
Housing material	aluminium
Housing	Aluminium with plastic covers (ABS)
Colour (housing)	RAL9016, RAL7035
Temperature range	-30 to +60°C
Dimensions (HxWxD)	see drawing
Weight	2.2kg
Parts supplied	Screw set, Thermostat switch, Screw terminal

Optional accessories

73177	WD-16/MK-W	Wall Mount with Swivel Head for VHM Weatherproof Housings, RAL9016
--------------	-------------------	--

VHM/ECLKB-210-W

Home | Security | Housings | for Boxed Cameras

Technical drawing

79416

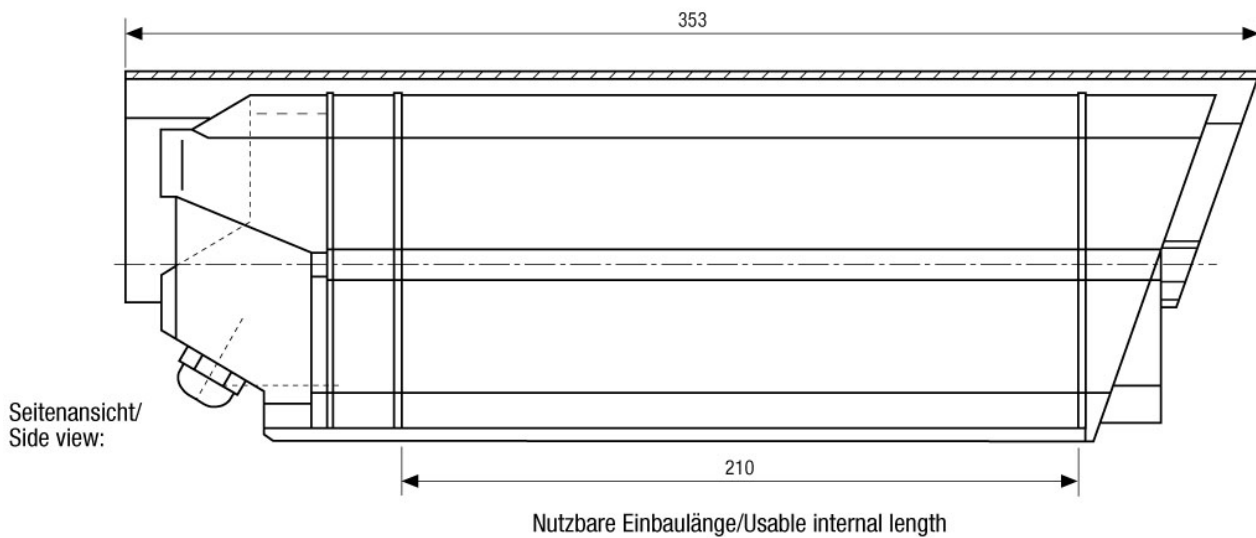
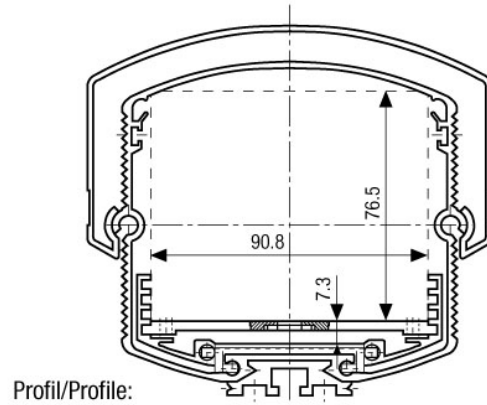
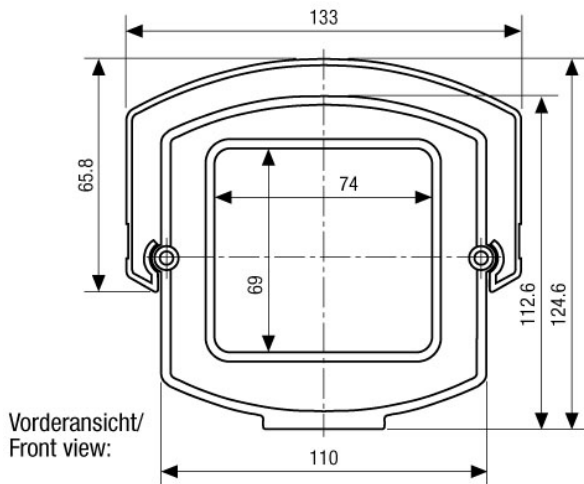

Maße/Dimensions: mm

SLD Security & Communications
The Old Forge, Ockham Lane, Ockham, Surrey GU236PH England
Phone +44.1483225633 · Fax +44.1483225634
sales@sld.co.uk · www.sld.co.uk

