

Video Security



EDMC/CWB

Wall or Pendant Mount Kit for EDMC Dome Camera and WDDG-1 Series

Art-No. 74097



Features

Wall/Ceiling Housing f. Minitrax and WDDG-1 Series

Specifications

Cable connection	We recommend a multicore cable with approx. 10mm diam., for example the eneo MCAB-1, edp no. 87404
Load capacity	5.0kg
Connection	1" PT thread
Protection rating	IP65 (in conjunction with the cable #87404 only)
Housing	Aluminium, Pipes: Steel
Colour	Light-grey polyester powder coated
Weight	1.2kg

Accessories

87404 / MCAB-1	Camera/PT Head Connecting Cable f. Video Power, RS-Control or Network, 1 Metre
-----------------------	--

Accessories of

74096 / EDMC-141	1/4" Colour High Speed Mini Dome Camera 10x Zoom Lens, 24VAC, 430TVL
71493 / WDDG-1	Dome Wall/Ceiling Flush Mount Housing for Board Cameras, Pantone Coolgray 1C

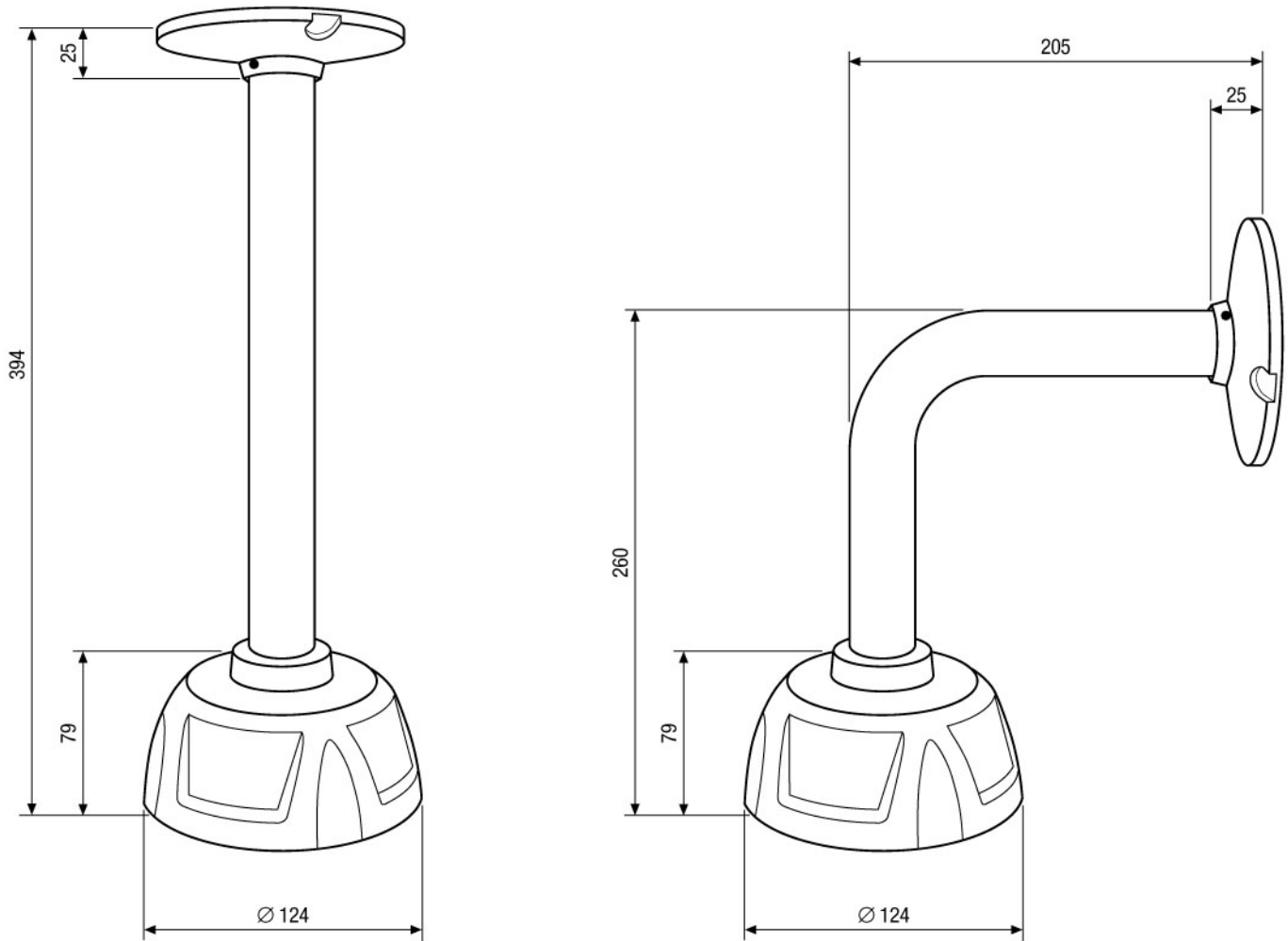

Maße/Dimensions: mm

SLD Security & Communications
The Old Forge, Ockham Lane, Ockham, Surrey GU236PH England
Phone +44.1483225633 · Fax +44.1483225633
sales@sld.co.uk · www.sld.co.uk

