

EDC-KBDM-3

Home | Security | Recording | Accessories

EDC-KBDM-3
System Keyboard w. Joystick, 5" Monitor 12VDC,
Fastrax Protocol

Art-Nr. 74092



Main Features

Programming and control of camera series:

Fastrax and Minitrax

For DVR series DLR1.2, DLR3/4, DTR, DIR and DPR

Supports up to 254 cameras

Joystick control of PTZ functions

Built-in 5" (12.7cm) TFT/LCD monitor

Programmable sequences and patterns

Preset position and pattern control

Auto and random scanning

Auxiliary operations

Alarm handling and alarm log

PTZ control with Eneo Fastrax IIE protocol

Specifications

Integrated monitor	TFT/LCD monitor (5"/12.7cm screen size)
Weight	1.9kg
Video input	1Vp-p, CVBS, 75ohms
Adjustment	Brightness and colour
Supply voltage	12VDC (connection to the Junction box, 230VAC PSU included)
Site control (direct mode operation)	Keys select cameras and monitors, operate presets, patterns, auxiliaries, and sequences. Camera functions: pan, tilt, zoom, focus, iris for fixed or variable speed control of the camera series Fastrax, Minitrax
Protocols	Fastrax IIE and Pelco P&D
Interfaces external storage	3x RS-485, RJ45 (8-pin). 1x KBD (For connection of the junction box: Dome camera series Fastrax), 1x DVR (Recorder series DLR2)
Remote control	Control of the camera series Fastrax and Minitrax. Recorder series DLR1.2, DLR3/4, DTR, DIR and DPR. Fastrax & Pelco D&P protocol
Power consumption	approx. 10watts

EDC-KBDM-3

(Continuation Specifications)

Temperature range	0 ~+50°C
Dimensions (HxWxD)	88 (120mm incl. Joystick) x400x230mm
Parts supplied	System keyboard, Junction box with connection cable and PSU
Certificates	CE

EDC-KBDM-3

Home | Security | Recording | Accessories

Technical drawing

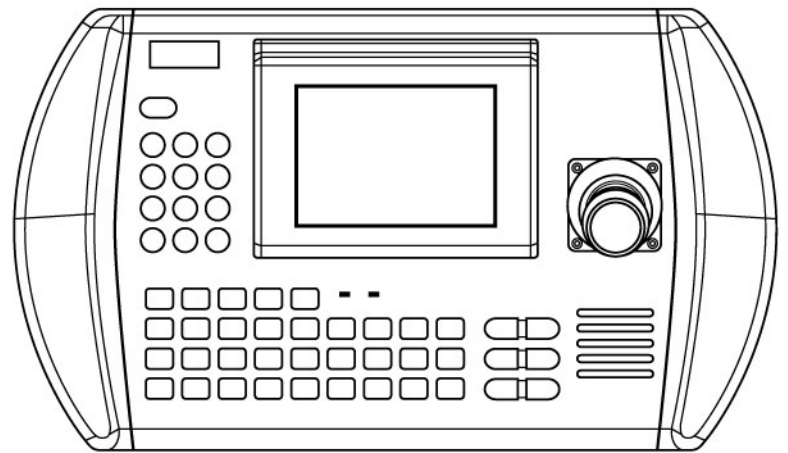
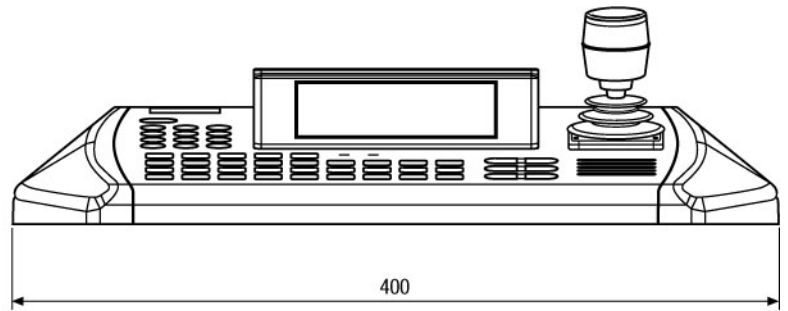
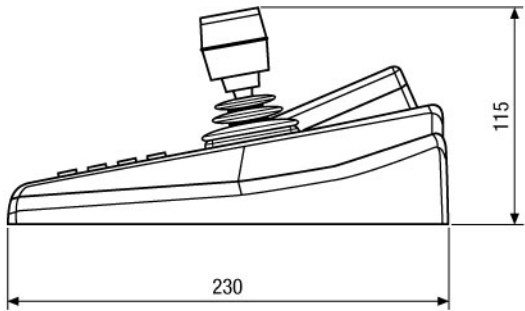

Maße/Dimensions: mm

SLD Security & Communications
The Old Forge, Ockham Lane, Ockham, Surrey GU236PH England
Phone +44.1483225633 · Fax +44.1483225634
sales@sld.co.uk · www.sld.co.uk

